

11

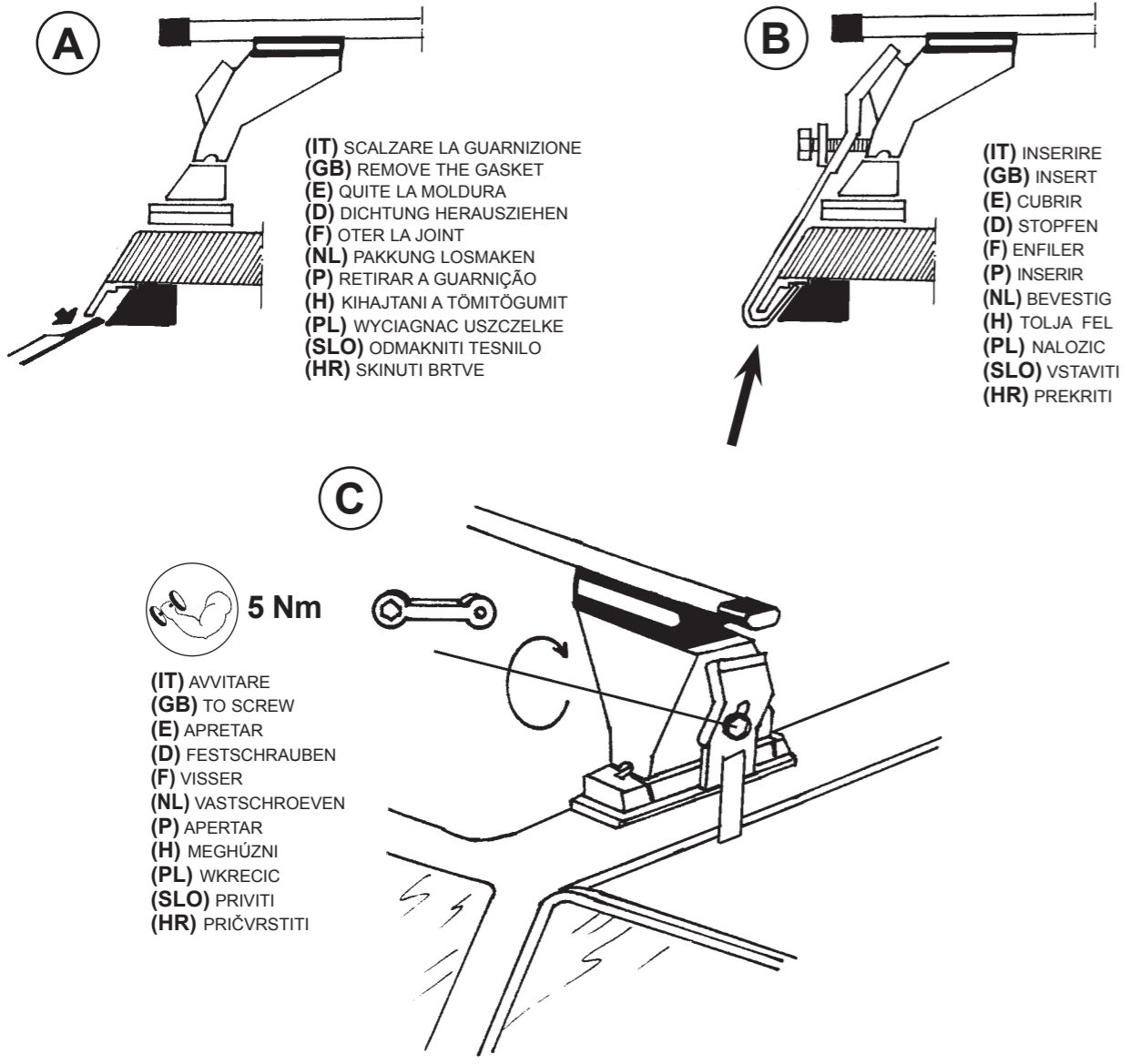

(IT) SCALZARE LA GUARNIZIONE
(GB) REMOVE THE GASKET
(E) QUITTE LA MOLDURA
(D) DICHTUNG HERAUSZIEHEN
(F) OTER LA JOINT
(NL) PAKKUNG LOSMAKEN
(P) RETIRAR A GUARNIÇÃO
(H) KIHAJTANI A TÖMITÖGUMIT
(PL) WYCIAGNAC USZCZELKE
(SLO) ODMAKNITI TESNILO
(HR) SKINUTI BRTVE

(IT) INSERIRE
(GB) INSERT
(E) CUBRIR
(D) STOPFEN
(F) ENFILER
(P) INSERIR
(NL) BEVESTIG
(H) TOLJA FEL
(PL) NALOZIC
(SLO) VSTAVITI
(HR) PREKRITI

5 Nm

(IT) AVVITARE
(GB) TO SCREW
(E) APRETAR
(D) FESTSCHRAUBEN
(F) VISSER
(NL) VASTSCHROEVEN
(P) APERTAR
(H) MEGHÚZNI
(PL) WKRECIC
(SLO) PRIVITI
(HR) PRIČVRSTITI

40164 AL

40164 AL

40164 AL

(IT) Attenzione: Istruzioni di montaggio per barre in alluminio.
(GB) Attention: Mounting instructions for aluminium bar carriers.
(E) Atencion: Instrucciones de montaje para barras portatodo en aluminio.
(D) Achtung: Montageanweisungen für Aluminium-Lastenträger.
(F) Attention: Notices de montage pour barres de portage en aluminium.
(NL) Attentie: Handleiding voor dakdragers gemaakt van aluminium.
(P) Atenção: Instruções de montagem para barras de tejadilho em alumínio.
(H) Szerelési utasítás alumínium tartórudakhoz.
(PL) Uwaga: Instrukcja montażu bagazników wykonanych ze aluminium.
(SLO) Pozor: Navodila za montažo nosilcev prtljažnika - aluminijastih.
(HR) Uputstvo za montažu aluminijaskih nosača.

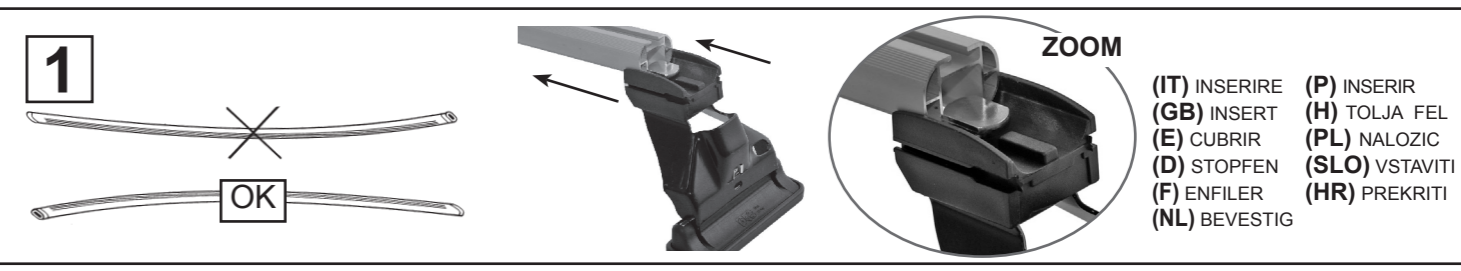

2

(IT) MODELLI AUTO (GB) CARS (E) COCHES (D) WAGEN (F) VOITURES	(NL) AUTO (P) MODELO AUTO (H) AUTÓ TIPUS (PL) MODELE SAMOCHODÓW (SLO) MODELI AVTOMOBILOV (HR) MODELI AUTA	(IT) ANTERIORE (GB) FRONT (E) DELANTERO (D) VORDERE (F) AVANT	(NL) VOORSTE G. (P) À FRENTE (H) ELSÓ RÚD (PL) PRZOD (SLO) SPREDAJ (HR) PREDNJI
TESLA Model 3 4P (18>)	22 mm	(IT) POST. (GB) REAR (E) TRASERO (D) HINTERE (F) ARRIERE	(NL) ACHTERSTE G. (P) ATRÁS (H) HÁTSÓ RÚD (PL) TYŁ (SLO) ZADAJ (HR) STRAŽNJI
		57 mm	

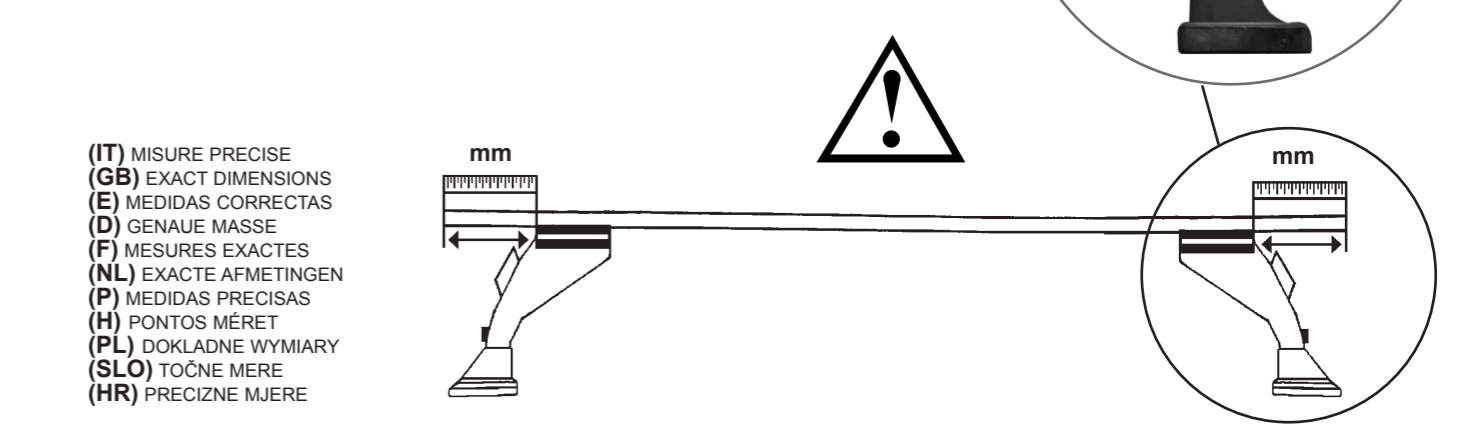

(IT) MISURE PRECISE
(GB) EXACT DIMENSIONS
(E) MEDIDAS CORRECTAS
(D) GENAUE MASSE
(F) MESURES EXACTES
(NL) EXACTE AFMETINGEN
(P) MEDIDAS PRECISAS
(H) PONTOS MÉRET
(PL) DOKŁADNE WYMIARY
(SLO) TOČNE MERE
(HR) PRECIZNE MJERE

12

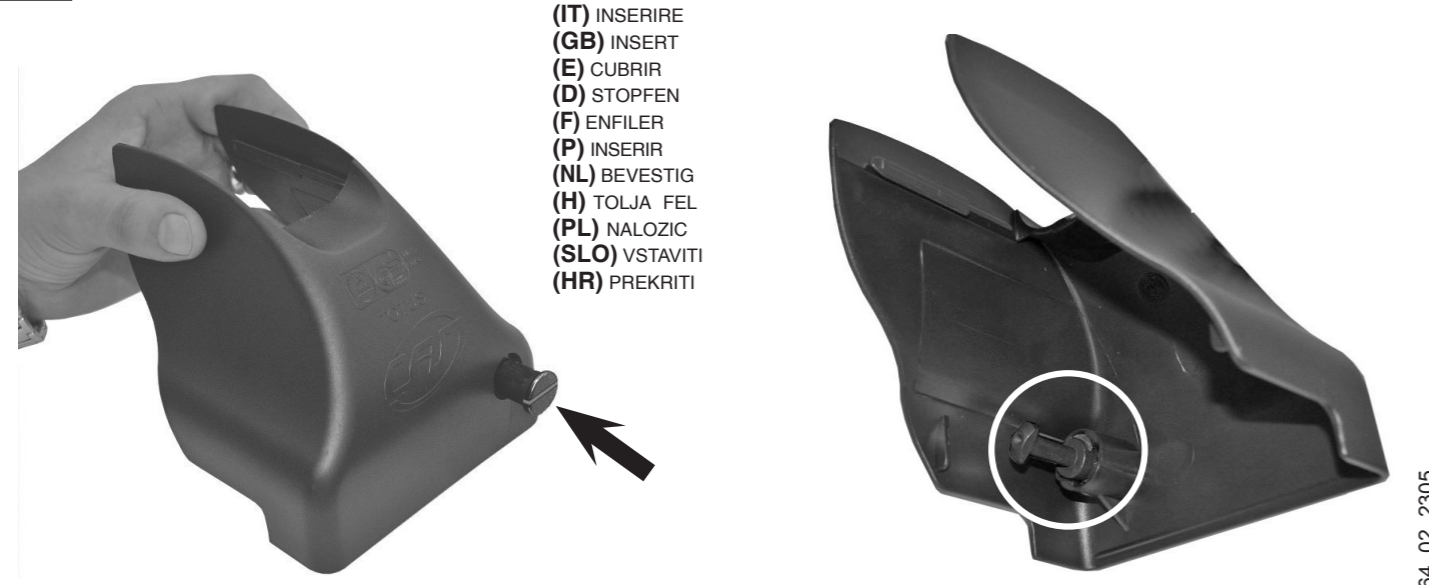

(IT) INSERIRE
(GB) INSERT
(E) CUBRIR
(D) STOPFEN
(F) ENFILER
(P) INSERIR
(NL) BEVESTIG
(H) TOLJA FEL
(PL) NALOZIC
(SLO) VSTAVITI
(HR) PREKRITI

IST_40164_02_2305



(IT) AVVITARE (A FONDO)
(GB) TO SCREW (DOWN)
(E) APRETAR (A FONDO)
(D) FESTSCHRAUBEN
(F) VISSER (À FOND)
(NL) VASTSCHROEVEN
(P) APERTAR POR BAIXO
(H) MEGHÚZNI
(PL) WKRECIC DO KONCA
(SLO) PRIVITI (DO KONCA)
(HR) PRIČVRSTITI (DO KRAJA)

10 Nm

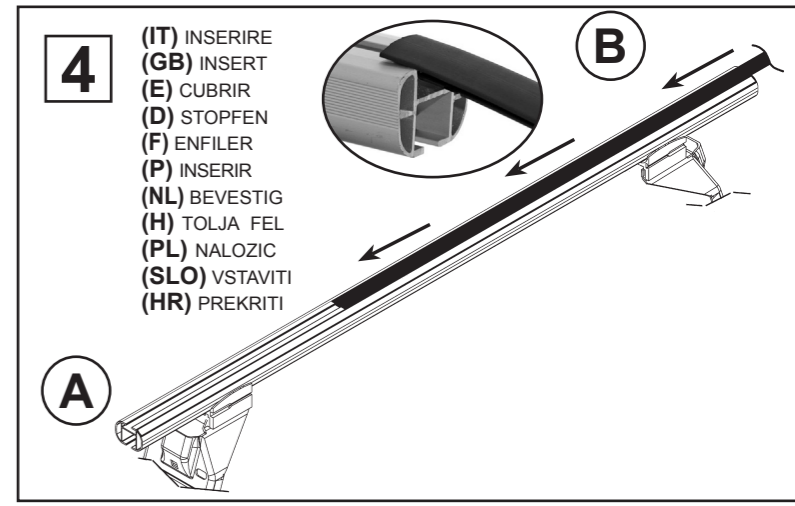

(IT) INSERIRE
(GB) INSERT
(E) CUBRIR
(D) STOPFEN
(F) ENFILER
(P) INSERIR
(NL) BEVESTIG
(H) TOLJA FEL
(PL) NALOZIC
(SLO) VSTAVITI
(HR) PREKRITI

5

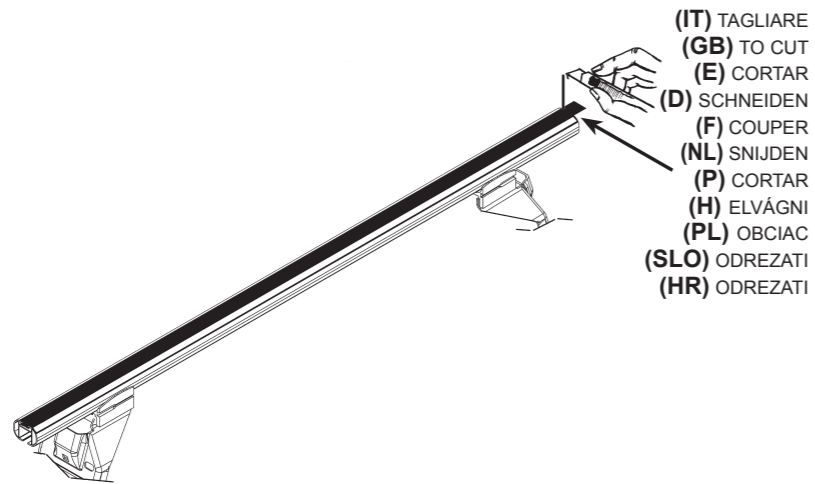

(IT) TAGLIARE
(GB) TO CUT
(E) CORTAR
(D) SCHNEIDEN
(F) COUPER
(NL) SNIJDEN
(P) CORTAR
(H) ELVÁGNI
(PL) OBCIAC
(SLO) ODREZATI
(HR) ODREZATI

6

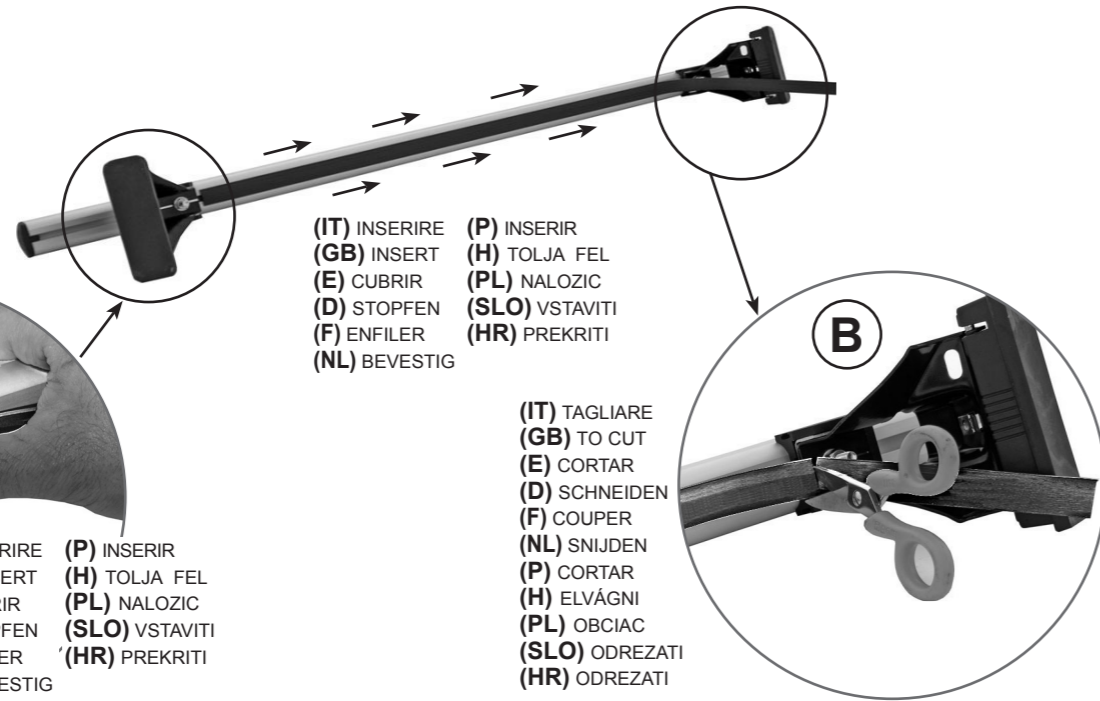

(IT) INSERIRE (P) INSERIR
(GB) INSERT (H) TOLJA FEL
(E) CUBRIR (PL) NALOZIC
(D) STOPFEN (SLO) VSTAVITI
(F) ENFILER (HR) PREKRITI
(NL) BEVESTIG

(IT) TAGLIARE
(GB) TO CUT
(E) CORTAR
(D) SCHNEIDEN
(F) COUPER
(NL) SNIJDEN
(P) CORTAR
(H) ELVÁGNI
(PL) OBCIAC
(SLO) ODREZATI
(HR) ODREZATI

(IT) INSERIRE (P) INSERIR
(GB) INSERT (H) TOLJA FEL
(E) CUBRIR (PL) NALOZIC
(D) STOPFEN (SLO) VSTAVITI
(F) ENFILER (HR) PREKRITI
(NL) BEVESTIG

7

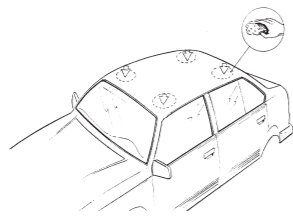

(IT) PULIRE IL TETTO
(GB) CLEAN THE ROOF
(E) LIMPIAR EL TECHO
(D) DACH REINIGEN
(F) NETTOYER LE TOIT
(NL) DAK SCHOONMAKEN
(P) LIMPAR O TEJADILHO
(H) TISZTITSA MEG A TETŐT
(PL) WYCZYSCIC DACH
(SLO) OČISTITI STREHO
(HR) ČIŠĆENJE KROVA

8



(IT) MODELLI AUTO
(GB) CARS
(E) COCHES
(D) WAGEN
(F) VOITURES
(NL) AUTO
(P) MODELO AUTO
(H) AUTÓ TIPUS
(PL) MODELE SAMOCHODÓW
(SLO) MODELI AVTOMOBILOV
(HR) MODELI AUTA

(IT) ANTERIORE
(GB) FRONT
(E) DELANTERO
(D) VORDERE
(F) AVANT
(NL) VOORSTE G.
(P) À FRENTE
(H) ELSŐ RÚD
(PL) PRZOD
(SLO) SPREDAJ
(HR) PREDNJI

(IT) POSTERIORE
(GB) REAR
(E) TRASERO
(D) HINTERE
(F) ARRIERE
(NL) ACHTERSTE G.
(P) ATRÁS
(H) HÁTSÓ RÚD
(PL) TYŁ
(SLO) ZADAJ
(HR) STRAŽNJI

TESLA Model 3 4P (18>)

22

22

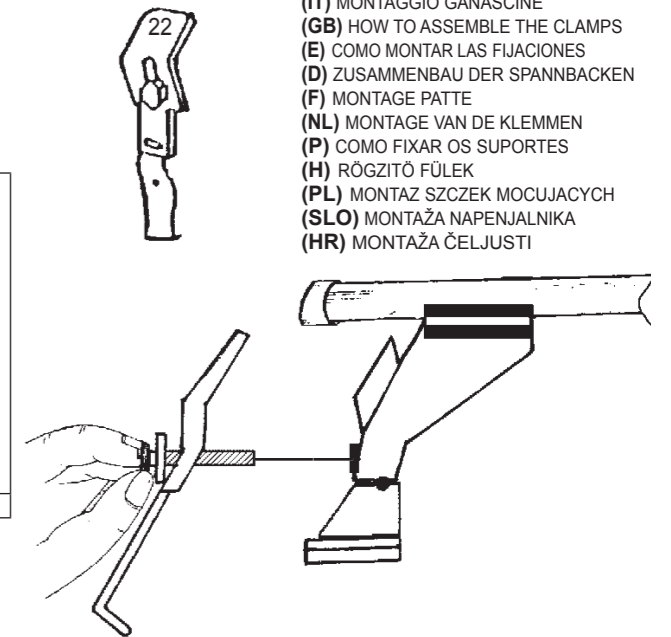

(IT) MONTAGGIO GANASCINE
(GB) HOW TO ASSEMBLE THE CLAMPS
(E) COMO MONTAR LAS FIJACIONES
(D) ZUSAMMENBAU DER SPANNBACKEN
(F) MONTAGE PATTE
(NL) MONTAGE VAN DE KLEMMEN
(P) COMO FIXAR OS SUPORTES
(H) RÖGZITŐ FÜLEK
(PL) MONTAZ SZCZEK MOCUJACYCH
(SLO) MONTAŽA NAPENJALNIKA
(HR) MONTAŽA ČELJUSTI

9

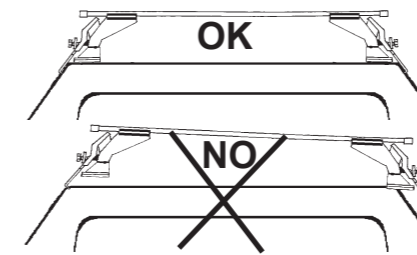

(IT) CENTRARE IL P. TUTTO SUL TETTO
(GB) CENTRE THE UNIVERSAL BAR CARRIER ON THE ROOF
(E) CENTRAR EL PORTAEQUIPAJES SOBRE EL TECHO
(D) LASTENTRÄGER AUF DEM DACH ZENTRIEREN
(F) CENTRER LE PORTE-TOUT SUR LE TOIT
(NL) PLAATS DE UNIVERSELE DRAGER IN HET MIDDEN VAN HET DAK
(P) CENTRAR AS BARRAS PORTA BAGAGENS NO TEJADILHO
(H) HELYEZZE KÖZÉPRE A RUDAKAT
(PL) WYSRODKOWAC BAGAZNIK NA DACHU
(SLO) CENTRIRATI PRTLJAŽNIK NA STREHO
(HR) CENTRIRATI NOSAČE NA KROV

10

(IT) MODELLI SENZA PREDISPOSIZIONE DELLA CASA AUTO
(GB) CARS WITHOUT PRE-EXISTING FIXING POINT
(E) PARA COCHES SIN PREDISPOSICION DEL FABRICANTE
(D) AUTOS OHNE VOM HERSTELLER VORGESEHENE BEFESTIGUNGSPUNKTE
(F) VOITURES SANS POINTS DE RÉPÈRE PRÉVUS PAR LE CONSTRUCTEUR
(NL) AUTO'S ZONDER DOOR DE FABRIKANT VOORZIENE BEVESTIGINGSPUNTEN
(P) VIATURAS SEM PONTOS DE FIXAÇÃO DO CONSTRUTOR PRÉ-EXISTENTES
(H) FELHELYEZES GYÁRI JELŐLÉS NÉLKÜLI AUTÓKRA
(PL) SAMOCHODY BEZ PRZEWIDZIANYCH PUNKTOW UMOCOWANIA
(SLO) MODELI Z NEPREDVIDENIM LEŽIŠČEM S STRANI PROIZVAJALCA
(HR) TVORNIČKI NEPRIPREMLJENI MODELI

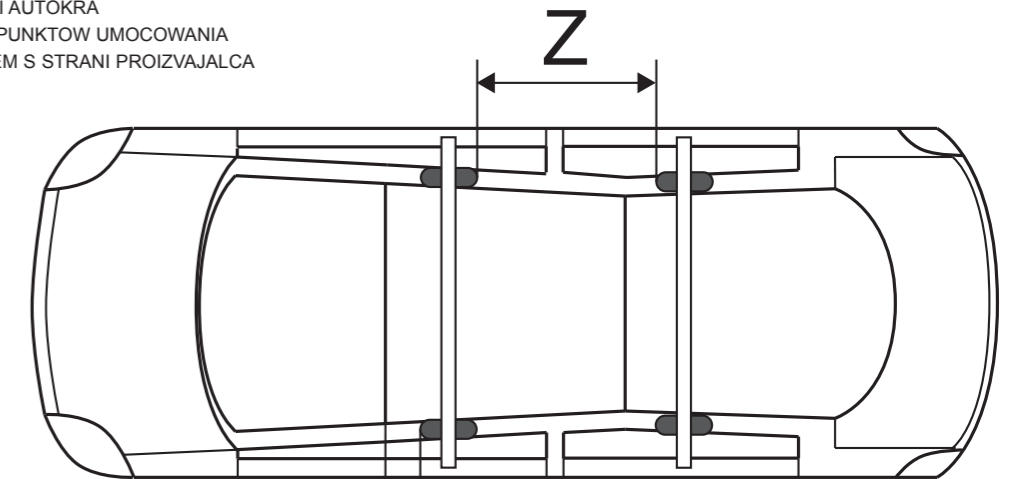

(IT) MODELLI AUTO
(GB) CARS
(E) COCHES
(D) WAGEN
(F) VOITURES
(NL) AUTO
(P) MODELO AUTO
(H) AUTÓ TIPUS
(PL) MODELE SAMOCHODÓW
(SLO) MODELI AVTOMOBILOV
(HR) MODELI AUTA

T

Z

TESLA Model 3 4P (18>)

110 mm

650 mm

13

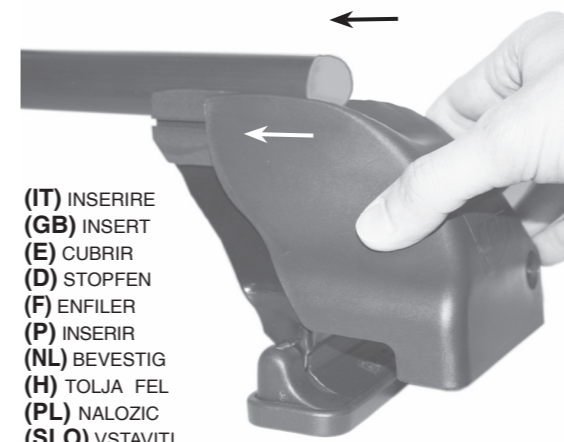

(IT) INSERIRE
 (GB) INSERT
 (E) CUBRIR
 (D) STOPFEN
 (F) ENFILER
 (P) INSERIR
 (NL) BEVESTIG
 (H) TOLJA FEL
 (PL) NALOZIC
 (SLO) VSTAVITI
 (HR) PREKRITI

14



15



(IT) INSERIRE
 (GB) INSERT
 (E) CUBRIR
 (D) STOPFEN
 (F) ENFILER
 (P) INSERIR
 (NL) BEVESTIG
 (H) TOLJA FEL
 (PL) NALOZIC
 (SLO) VSTAVITI
 (HR) PREKRITI



16

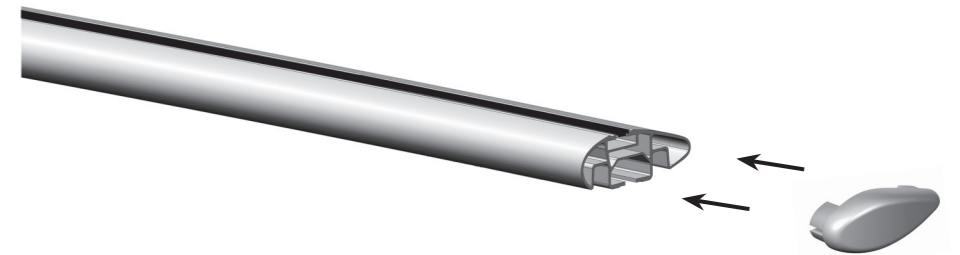

(IT) INSERIRE
 (GB) INSERT
 (E) CUBRIR
 (D) STOPFEN
 (F) ENFILER
 (P) INSERIR
 (NL) BEVESTIG
 (H) TOLJA FEL
 (PL) NALOZIC
 (SLO) VSTAVITI
 (HR) PREKRITI

40164 PARTS LIST

