

(IT) Attenzione: Istruzioni di montaggio per barre in ferro.
(GB) Attention: Mounting instructions for steel bar carriers.
(E) Atención: Instrucciones de montaje para barras portatodo en hierro.
(D) Achtung: Montageanweisungen für Stahl-Lastenträger.
(F) Attention: Notices de montage pour barres de portage en métal.
(NL) Attentie: Handleiding voor dakdragers gemaakt van ijzer.
(P) Atenção: Instrukções de montagem para barras de tejadilho em ferro.
(H) Szerelési utasítás acél tartórudakhoz.
(PL) Uwaga: Instrukcja montażu bagażników wykonanych ze stali.
(SLO) Pozor: Navodila za montažo nosilcev prtljane inika-æeleznh.
(HR) Uputstvo za montažu æeljeznih krovnih nosa»a.

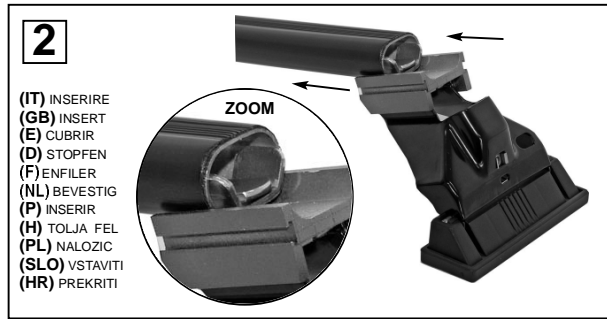

3

(IT) MODELLI AUTO (NL) AUTO (GB) CARS (P) MODELO AUTO (E) COCHES (H) AUTO TIPUS (D) WAGEN (SLO) MODELI AVTOMOBILOV (F) VOITURES (HR) MODELI AVTA	(NL) VOOR- STEG (IT) ANTERIORE (P) A FRENTE (GB) FRONT (H) ELSŐ RÚD (E) DELANTERO (PL) PRZÓD (D) VORDERE (SLO) SPREDAJ (F) AVANT (HR) PREDNJI	(NL) ACHTERSTE (IT) POST. (P) ATRAS (GB) REAR (H) MÁSODIK RÚD (E) TRASERO (PL) TYŁ (D) HINTERE (SLO) ZADAJ (F) ARRIERE (HR) STRAENJI	(NL) ACHTERSTE (IT) POST. (P) ATRAS (GB) REAR (H) HARMADIK RÚD (E) TRASERO (PL) TYŁ (D) HINTERE (SLO) ZADAJ (F) ARRIERE (HR) STRAENJI	(NL) ACHTERSTE G. (IT) POST. (P) ATRAS (GB) REAR (H) NEGYEDIK RÚD (E) TRASERO (PL) TYŁ (D) HINTERE (SLO) ZADAJ (F) ARRIERE (HR) STRAENJI
TOYOTA HIACE	76mm.	79mm.	80mm.	81 mm.

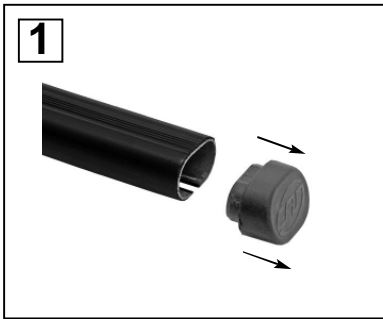