



2164

(IT) ISTRUZIONI DI MONTAGGIO (GB) FITTING INSTRUCTIONS (F) INSTRUCTIONS DE MONTAGE (D) MONTAGEANWEISUNGEN (E) INSTRUCCIONES PARA SU MONTAJE (P) INSTRUÇÕES DE MONTAGEM (NL) MONTAGE INSTRUCTIES (H) SZERELÉSI UTASÍTÁS (PL) INSTRUKCJA MONTAZU (SLO) NAVODILA ZA MONTAŽO (HR) UPUTSTVO ZA MONTAŽU

1

(IT) INSERIRE
(GB) INSERT
(E) CUBRIR
(D) EINSCHIEBEN
(F) ENFILER
(P) INSERIR
(NL) BEVESTIG

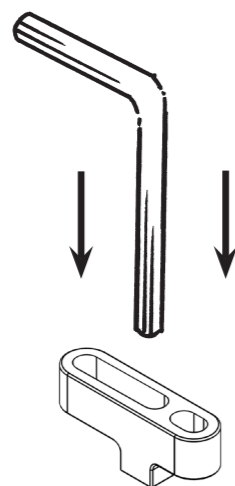

3

(IT) INSERTO
(GB) INSERT
(E) CUNA
(D) DÜBEL
(F) TAMPON
(NL) INVOEGSTUK
(H) BESZŰRÁS
(PL) WKŁADKA
(SLO) VLOŽKA
(HR) UMETAK

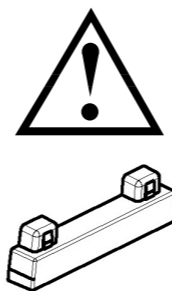

(IT) VEDERE LA TABELLA APPLICABILITA' ALLEGATA
(GB) SEE THE ATTACHED APPLICATION TABLE
(E) CONSULTE LA TABLA DE APLICABILIDAD ADJUNTA
(D) SIEHE DIE BEILIEGENDE ANWENDUNGSTABELLE
(F) VOIR LE TABLEAU D'APPLICATION ATTACHE'
(NL) KIJK IN DE BIJGEVOEGDE APPLICATIETABEL

SI/YES/YA/OUI

NO/NO/NEIN/NON

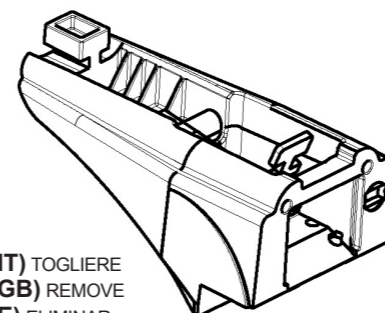
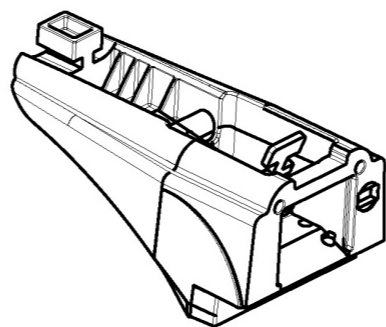

(IT) TOGLIERE
(GB) REMOVE
(E) ELIMINAR
(D) ENTFERNEN
(F) ENLEVER
(P) REMOVER
(NL) VERWIJDEREN
(H) ELTÁVOLÍT
(PL) USUNĄĆ
(SLO) ODSTRANITI
(HR) UKLONITI

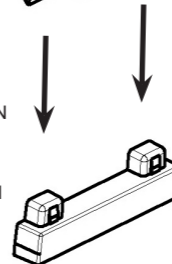

4

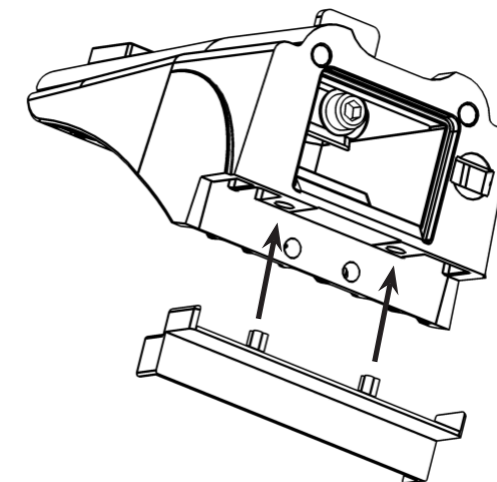
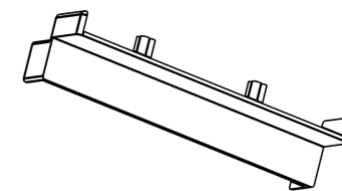

(IT) INSERIRE
(GB) INSERT
(E) CUBRIR
(D) EINSCHIEBEN
(F) ENFILER
(P) INSERIR
(NL) BEVESTIG
(H) TOLJA FEL
(PL) NAŁOŻIĆ
(SLO) VSTAVITI
(HR) UMETNUTI

(x4)

2



(IT) VEDERE LA TABELLA APPLICABILITA' ALLEGATA PER LA SCELTA DEL TIRANTE
(GB) SEE THE ATTACHED APPLICATION TABLE FOR THE COUPLER CHOICE
(E) CONSULTE LA TABLA DE APLICABILIDAD ADJUNTA PARA SELECCIONAR LOS TIRANTE APROPRIADO
(D) SIEHE DIE BEILIEGENDE ANWENDUNGSTABELLE UM DEN RICHTIGEN KUPPLER ZU WÄHLEN
(F) VOIR LE TABLEAU D'APPLICATION ATTACHE' AU FIN DE CHOISIR LE TIRANT LE PLUS CORRECT
(NL) KIJK IN DE BIJGEVOEGDE APPLICATIETABEL VOOR DE JUISTE KEUZE MONTAGEBEUGELS

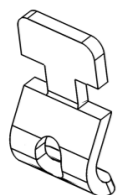

A

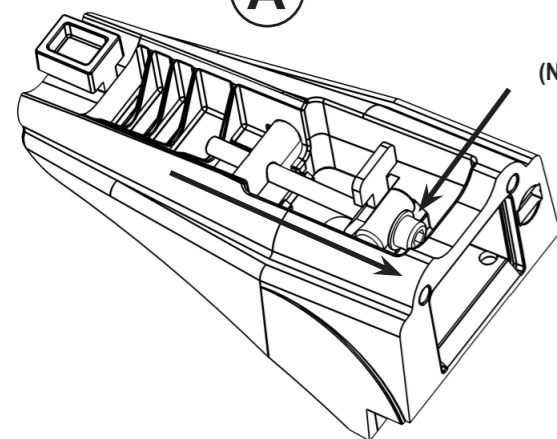

(IT) SVITARE
(GB) UNSCREW
(E) AFLOJAR
(D) ABSCHRAUBEN
(F) DEVISSER
(NL) OPENSCHROEVEN
(P) DESAPARAFUSAR
(H) KICSAVARNI
(PL) WYKRĘCIĆ
(SLO) ODVITI
(HR) ODVITI

(IT) MONTAGGIO TIRANTE 2
(GB) HOW TO ASSEMBLE COUPLER 2
(E) COMO MONTAR LOS TIRANTE 2
(D) ZUSAMMENBAU DER KOPPLER 2
(F) MONTAGE TIRANT 2
(NL) MONTAGE VAN DE TREKSTANG 2
(H) RÖGZÍTÓ BETÉT SZERELÉSE
(PL) WYMIANA ŁAPKI 2
(SLO) KAKO SESTAVITI SPOJ 2
(HR) UGRADNJA 2 ZAKAČKE



(IT) SOSTITUIRE
(GB) TO REPLACE
(E) APRETAR
(D) ERSETZEN
(F) REMPLACER
(NL) VERVANGEN
(H) CSERÉLJE ÁT 2A ÁBRA SZERINT
(PL) ZAMIENIĆ
(SLO) NAMESTITI NAZAJ
(HR) ZAMIJENITI



B

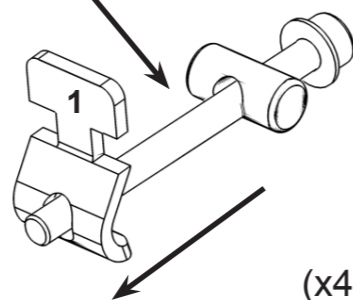

(x4)

5

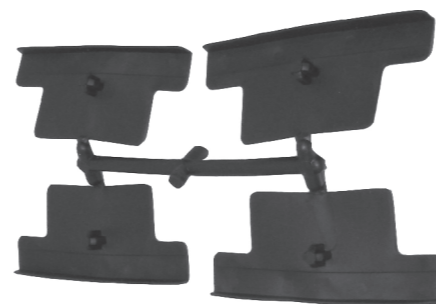

A

(IT) INSERIRE
(GB) INSERT
(E) CUBRIR
(D) EINSCHIEBEN
(F) ENFILER
(P) INSERIR
(NL) BEVESTIG
(H) TOLJA FEL
(PL) NAŁOŻIĆ
(SLO) VSTAVITI
(HR) PREKRITI

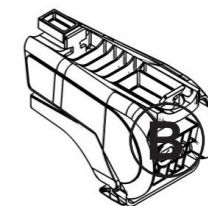

(x4)



2164 PARTS LIST

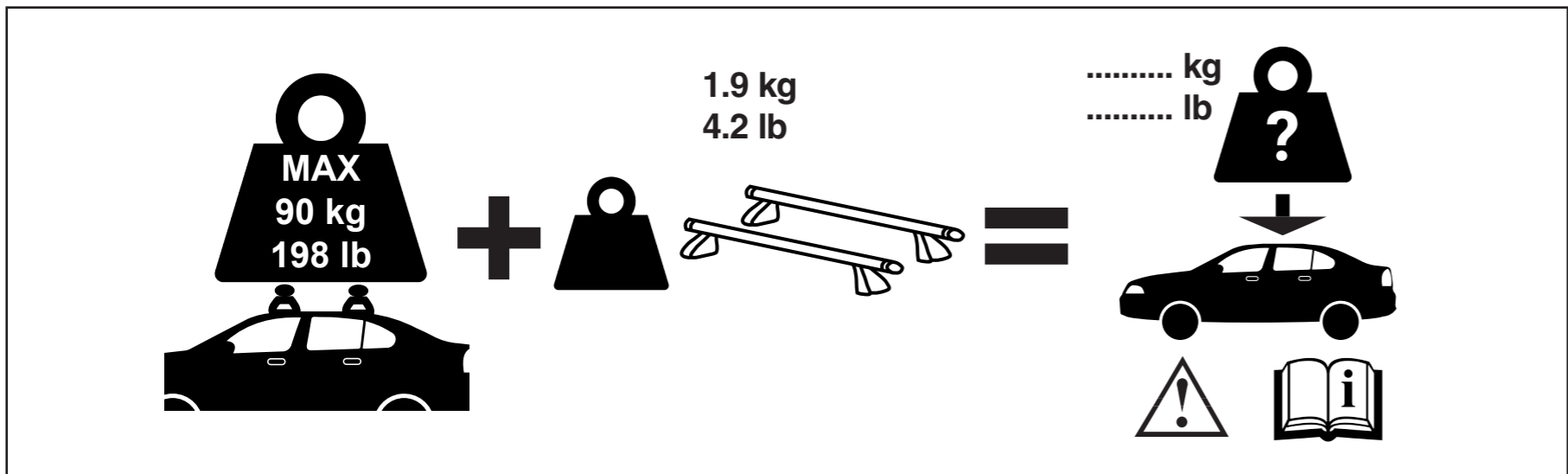
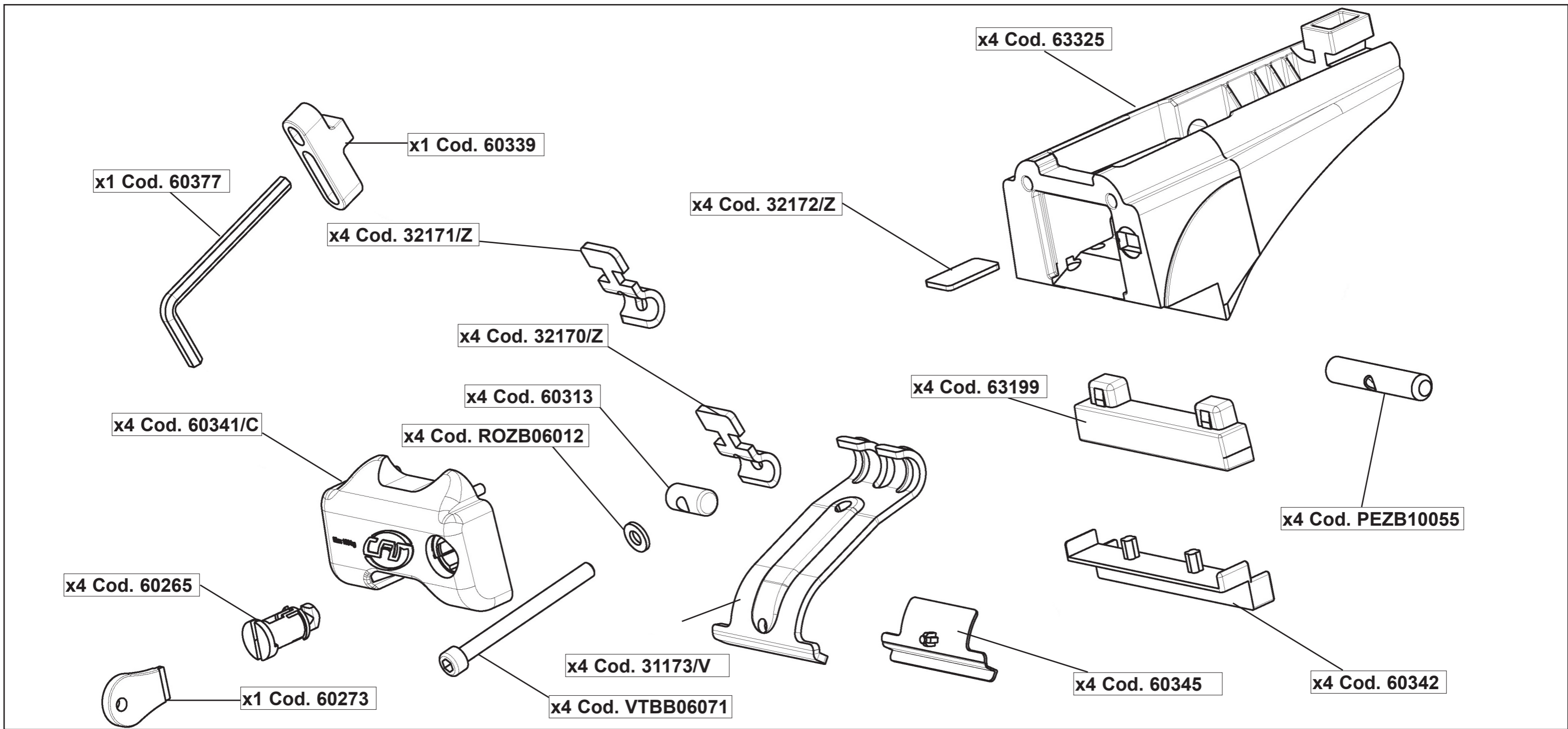

6

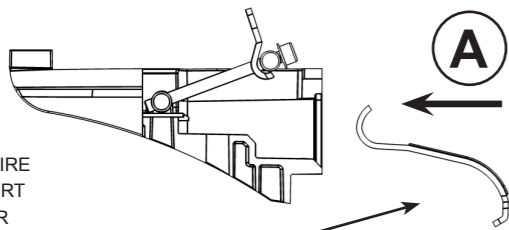

(IT) INSERIRE
(GB) INSERT
(E) CUBRIR
(D) EINSCHIEBEN
(F) ENFILER
(P) INSERIR
(NL) BEVESTIG
(H) TOLJA FEL
(PL) NALOZIC
(SLO) VSTAVITI
(HR) PREKRITI

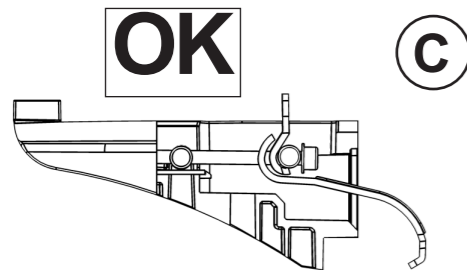
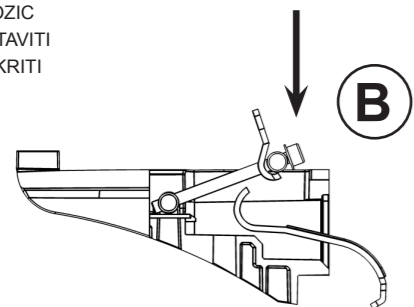

(x4)

7

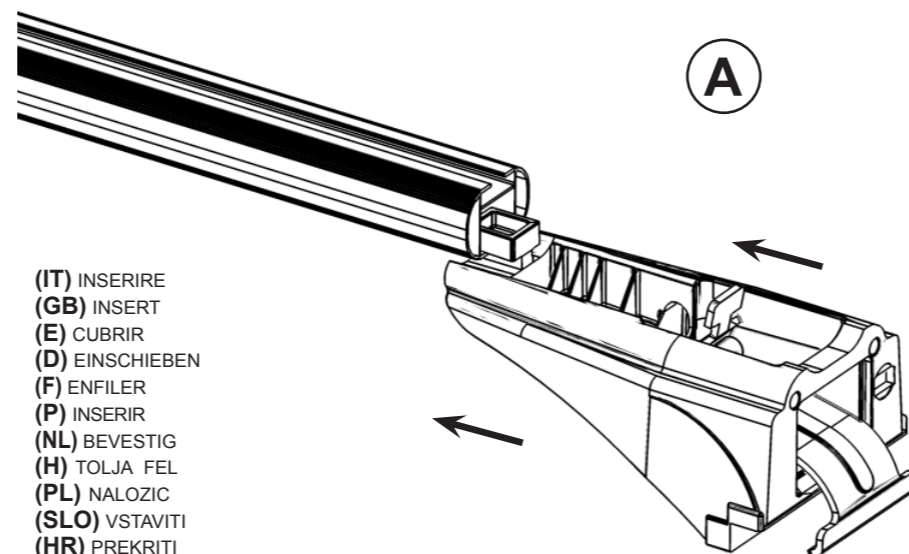

(IT) INSERIRE
(GB) INSERT
(E) CUBRIR
(D) EINSCHIEBEN
(F) ENFILER
(P) INSERIR
(NL) BEVESTIG
(H) TOLJA FEL
(PL) NALOZIC
(SLO) VSTAVITI
(HR) PREKRITI

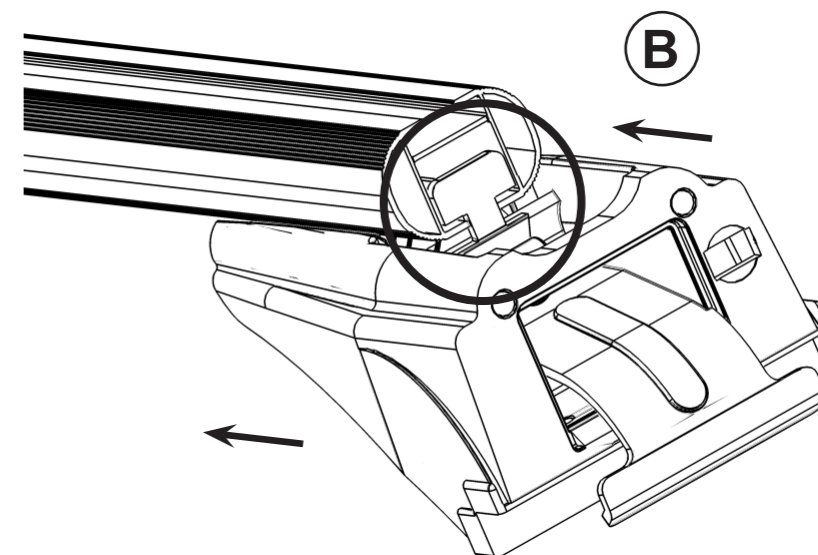

(x4)

8

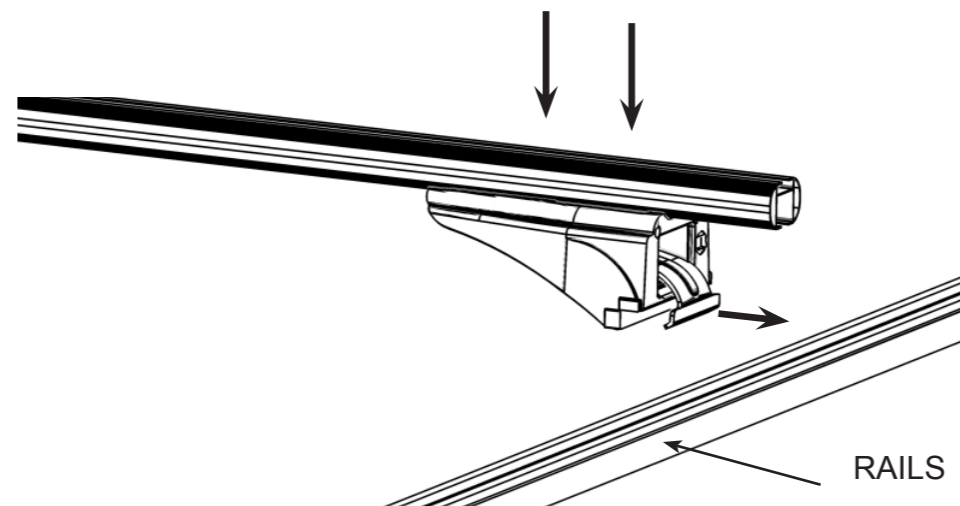

RAILS

9

(IT) CENTRARE IL P. TUTTO SUL TETTO
(GB) CENTRE THE UNIVERSAL BAR CARRIER ON THE ROOF
(E) CENTRAR EL PORTAEQUIPAJES SOBRE EL TECHO
(D) LASTENTRÄGER AUF DEM DACH ZENTRIEREN
(F) CENTRER LE PORTE-TOUT SUR LE TOIT
(NL) PLAATS DE UNIVERSELE DRAGER IN HET MIDDEN VAN HET DAK
(P) CENTRAR AS BARRAS PORTA BAGAGENS NO TEJADILHO
(H) HELYEZZE KÖZÉPRE A RUDAKAT
(PL) WYSRODKOWAC BAGAŻNIK NA DACHU
(SLO) CENTRIRATI PRTLJAŽNIK NA STREHO
(HR) CENTRIRATI NOSAČE NA KROV



10

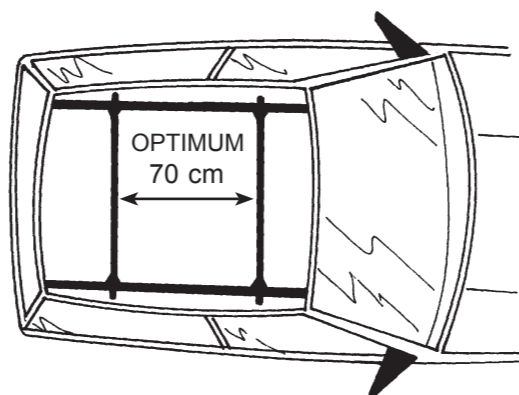

11

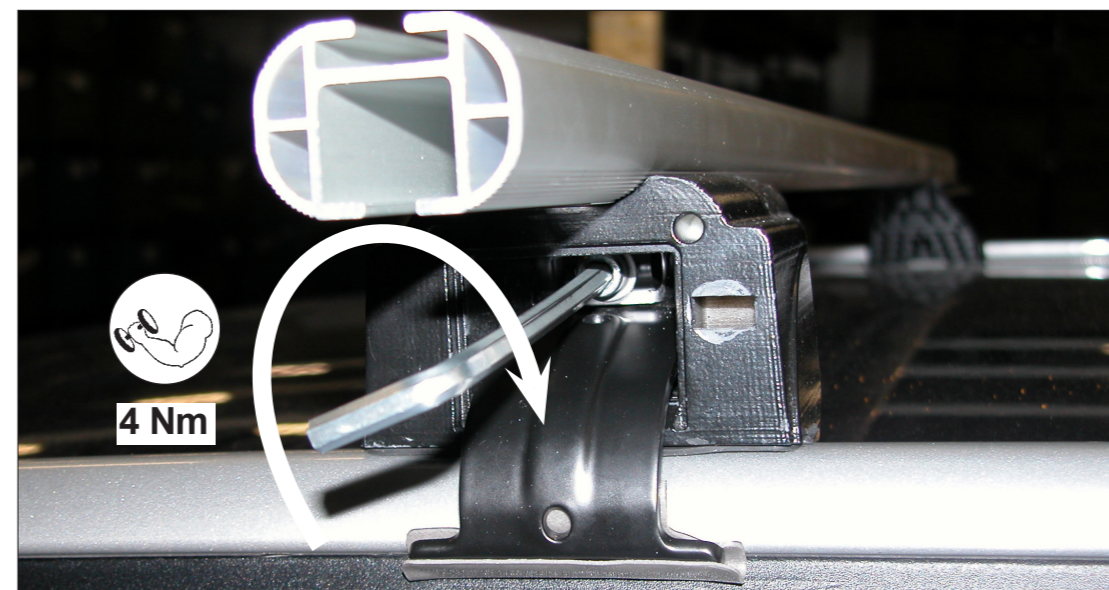

4 Nm

(IT) AVVITARE
(GB) TO SCREW
(E) APRETAR
(D) FESTSCHRAUBEN
(F) VISSER
(NL) VASTSCHROEVEN
(P) APERTAR
(H) MEGHÚZNI
(PL) WKRECIĆ
(SLO) PRIVITI
(HR) PRIČVRSTITI

(x4)

12

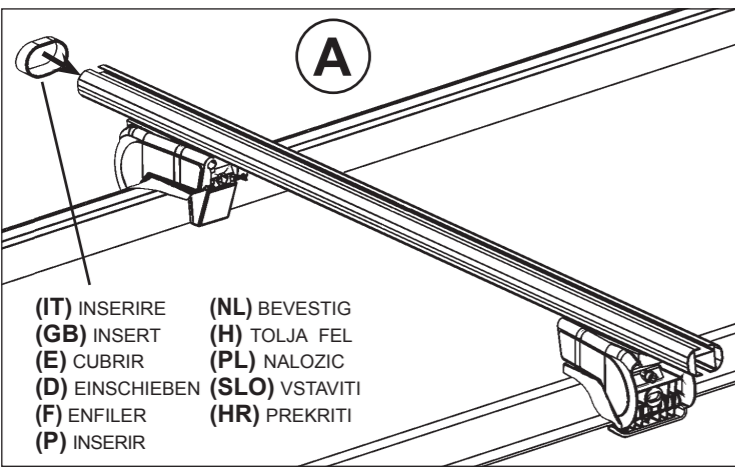

(IT) INSERIRE (NL) BEVESTIG
 (GB) INSERT (H) TOLJA FEL
 (E) CUBRIR (PL) NALOZIC
 (D) EINSCHIEBEN (SLO) VSTAVITI
 (F) ENFILER (HR) PREKRITI
 (P) INSERIR

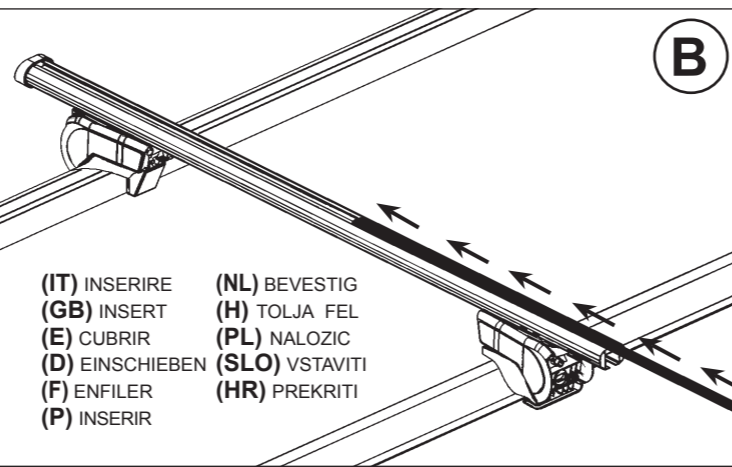

(IT) INSERIRE (NL) BEVESTIG
 (GB) INSERT (H) TOLJA FEL
 (E) CUBRIR (PL) NALOZIC
 (D) EINSCHIEBEN (SLO) VSTAVITI
 (F) ENFILER (HR) PREKRITI
 (P) INSERIR

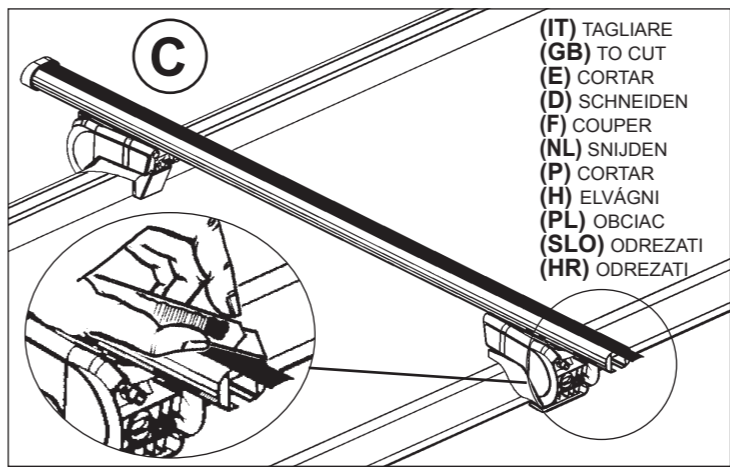

(IT) TAGLIARE (NL) BEVESTIG
 (GB) TO CUT (H) TOLJA FEL
 (E) CORTAR (PL) NALOZIC
 (D) SCHNEIDEN (SLO) VSTAVITI
 (F) COUPER (HR) PREKRITI
 (NL) SNIJDEN
 (P) CORTAR
 (H) ELVÁGNI
 (PL) OBCIAC
 (SLO) ODREZATI
 (HR) ODREZATI

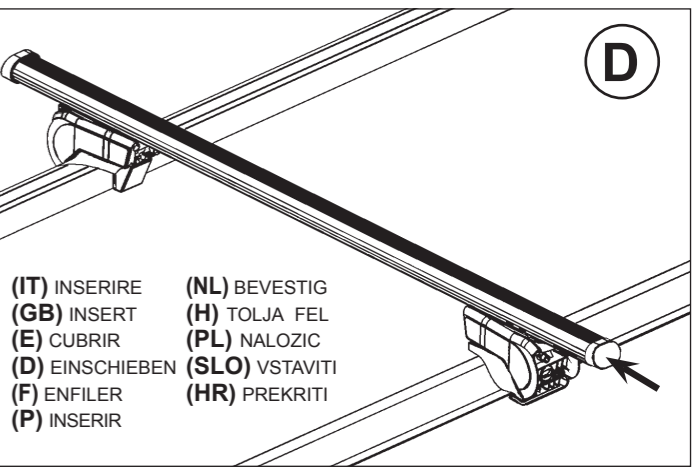

(IT) INSERIRE (NL) BEVESTIG
 (GB) INSERT (H) TOLJA FEL
 (E) CUBRIR (PL) NALOZIC
 (D) EINSCHIEBEN (SLO) VSTAVITI
 (F) ENFILER (HR) PREKRITI
 (P) INSERIR

13

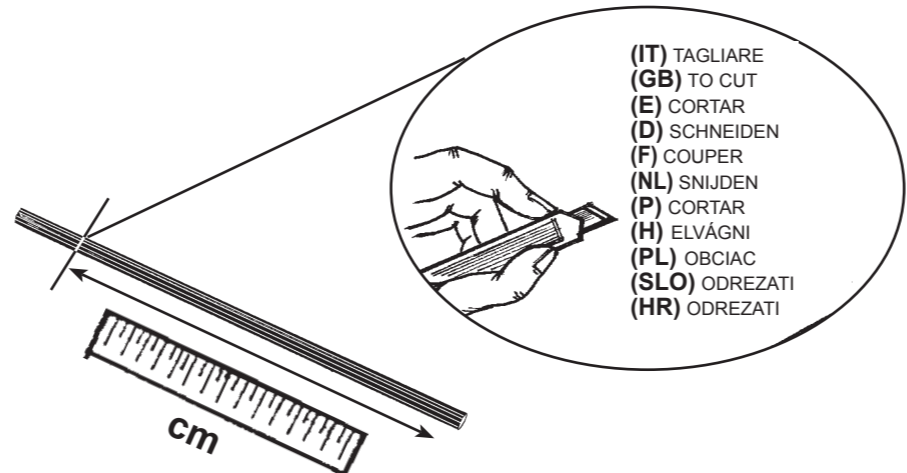
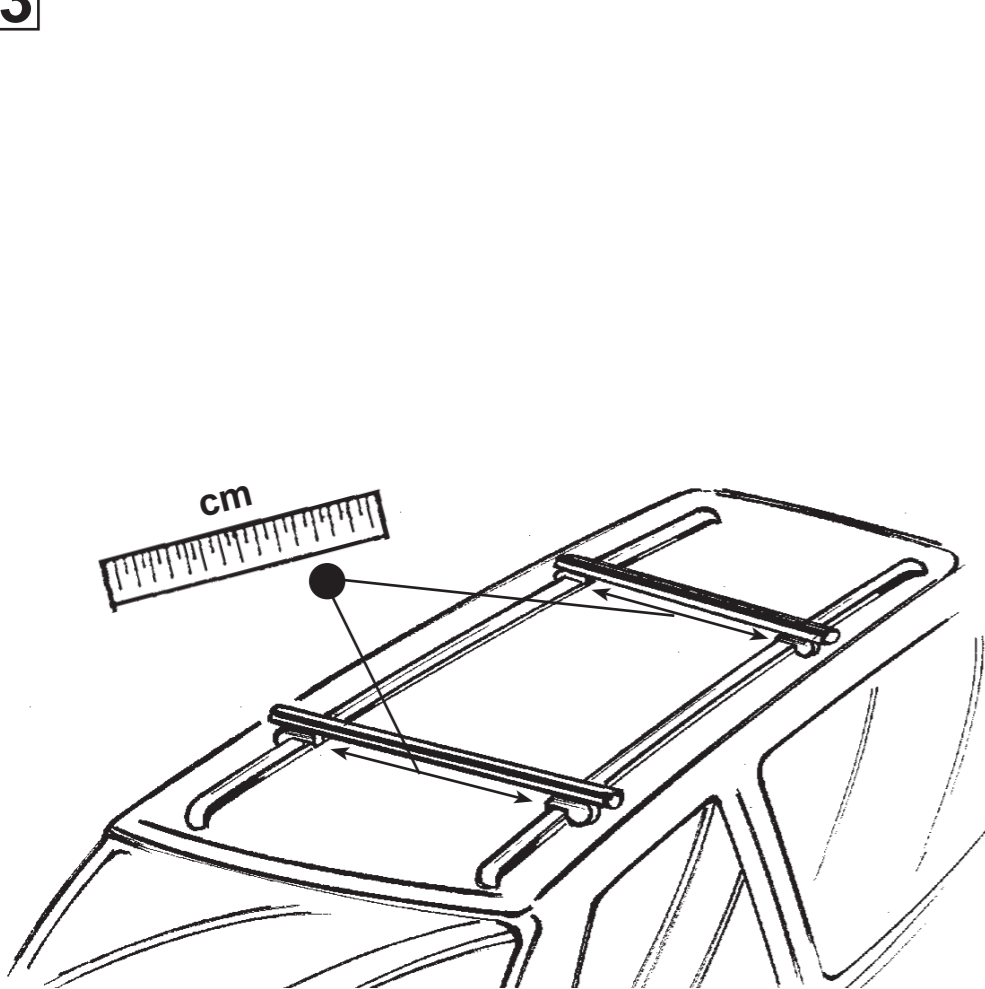

(IT) TAGLIARE (NL) BEVESTIG
 (GB) TO CUT (H) TOLJA FEL
 (E) CORTAR (PL) NALOZIC
 (D) SCHNEIDEN (SLO) VSTAVITI
 (F) COUPER (HR) PREKRITI
 (NL) SNIJDEN
 (P) CORTAR
 (H) ELVÁGNI
 (PL) OBCIAC
 (SLO) ODREZATI
 (HR) ODREZATI

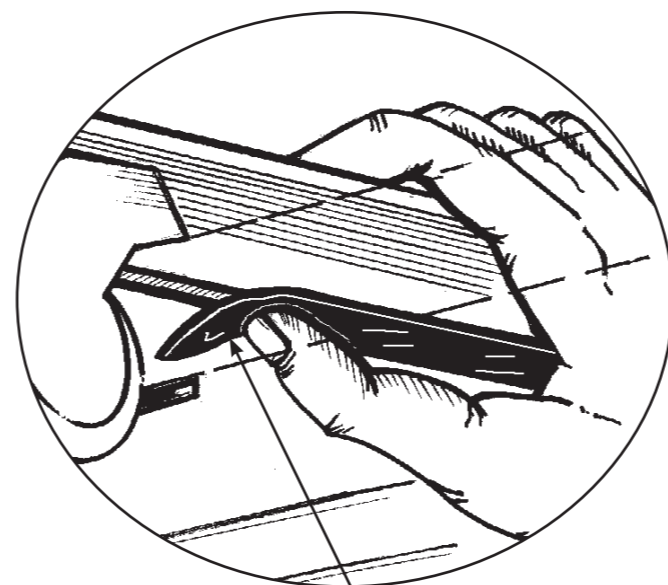

(IT) INSERIRE (NL) BEVESTIG
 (GB) INSERT (H) TOLJA FEL
 (E) CUBRIR (PL) NALOZIC
 (D) STOPFEN (SLO) VSTAVITI
 (F) ENFILER (HR) PREKRITI
 (P) INSERIR

(x2)

14

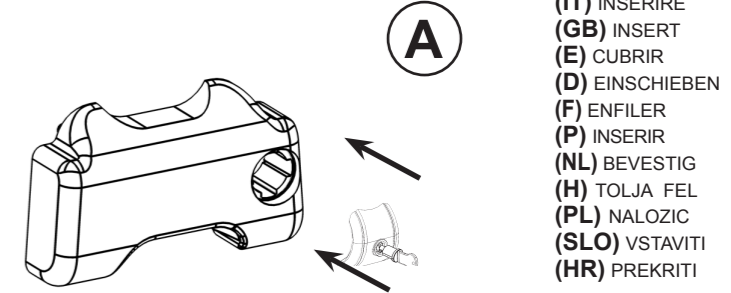

(IT) INSERIRE (NL) BEVESTIG
 (GB) INSERT (H) TOLJA FEL
 (E) CUBRIR (PL) NALOZIC
 (D) EINSCHIEBEN (SLO) VSTAVITI
 (F) ENFILER (HR) PREKRITI
 (P) INSERIR

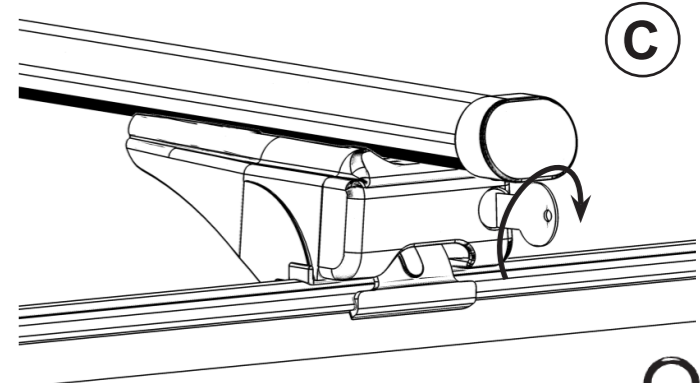
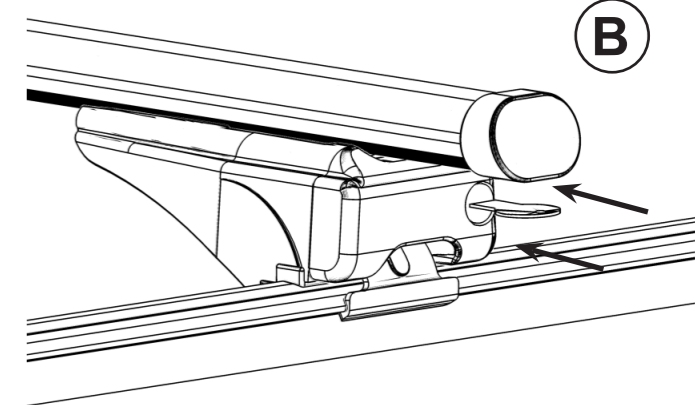

(x4)



6

(IT) INSERIRE
(GB) INSERT
(E) CUBRIR
(D) EINSCHIEBEN
(F) ENFILER
(P) INSERIR
(NL) BEVESTIG
(H) TOLJA FEL
(PL) NALOZIC
(SLO) VSTAVITI
(HR) PREKRITI

OK

(x4)

7

(IT) INSERIRE
(GB) INSERT
(E) CUBRIR
(D) EINSCHIEBEN
(F) ENFILER
(P) INSERIR
(NL) BEVESTIG
(H) TOLJA FEL
(PL) NALOZIC
(SLO) VSTAVITI
(HR) PREKRITI

(x4)

8

RAILS

9

(IT) CENTRARE IL P. TUTTO SUL TETTO
(GB) CENTRE THE UNIVERSAL BAR CARRIER ON THE ROOF
(E) CENTRAR EL PORTAEQUIPAJES SOBRE EL TECHO
(D) LASTENTRÄGER AUF DEM DACH ZENTRIEREN
(F) CENTRER LE PORTE-TOUT SUR LE TOIT
(NL) PLAATS DE UNIVERSELE DRAGER IN HET MIDDEN VAN HET DAK
(P) CENTRAR AS BARRAS PORTA BAGAGENS NO TEJADILHO
(H) HELYEZZE KÖZÉPRE A RUDAKAT
(PL) WYSRODKOWAC BAGAŻNIK NA DACHU
(SLO) CENTRIRATI PRTLJAŽNIK NA STREHO
(HR) CENTRIRATI NOSAČE NA KROV

NO **NO** **OK**

10

OPTIMUM
70 cm

11

4 Nm

(IT) AVVITARE
(GB) TO SCREW
(E) APRETAR
(D) FESTSCHRAUBEN
(F) VISSER
(NL) VASTSCHROEVEN
(P) APERTAR
(H) MEGHÚZNI
(PL) WKRECIC
(SLO) PRIVITI
(HR) PRIČVRSTITI

(x4)

12

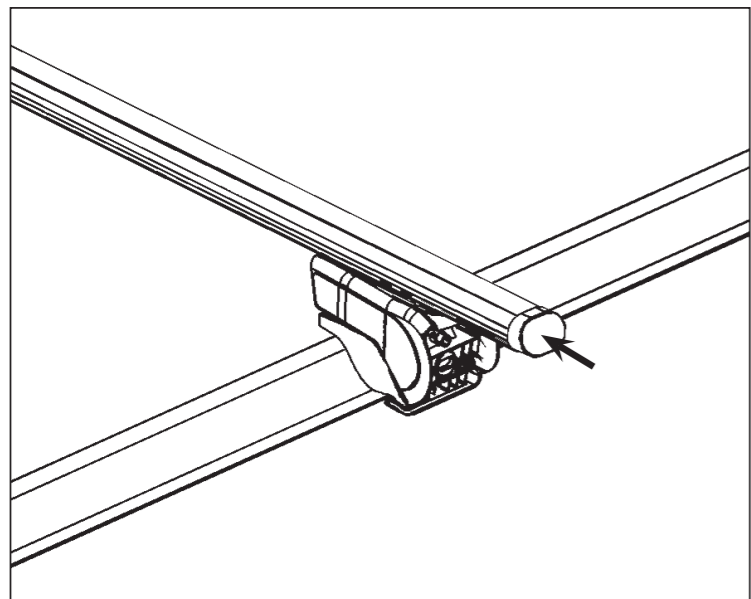

(IT) INSERIRE
 (GB) INSERT
 (E) CUBRIR
 (D) EINSCHIEBEN
 (F) ENFILER
 (P) INSERIR
 (NL) BEVESTIG
 (H) TOLJA FEL
 (PL) NALOZIC
 (SLO) VSTAVITI
 (HR) PREKRITI

(x4)

13

A

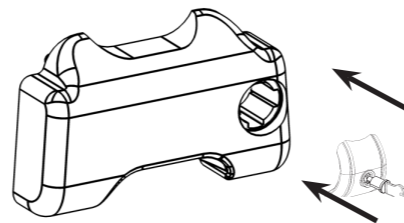

(IT) INSERIRE
 (GB) INSERT
 (E) CUBRIR
 (D) EINSCHIEBEN
 (F) ENFILER
 (P) INSERIR
 (NL) BEVESTIG
 (H) TOLJA FEL
 (PL) NALOZIC
 (SLO) VSTAVITI
 (HR) PREKRITI

B

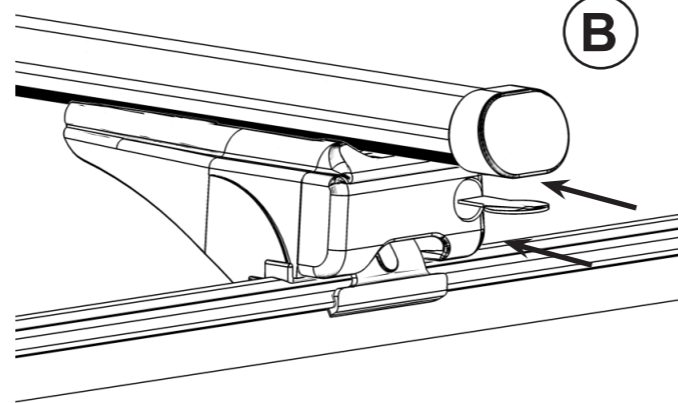

C

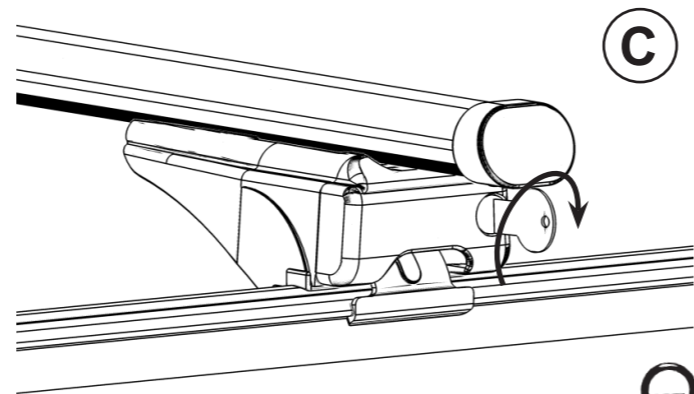

(x4)

(IT) MODELLI AUTO (GB) CARS (E) COCHES (D) WAGEN (F) VOITURES (NL) AUTO (P) MODELO AUTO (H) AUTO TIPUS (PL) MODELE SAMOCHODOW (SLO) MODELI AVTOMOBILOV (HR) MODELI AUTA	(IT) INSERTO (GB) INSERT (E) CLAVE (D) DÜBEL (F) TAMPON (NL) INVOEGSTUK (H) BESZURAS (PL) WKŁADKA (SLO) VLOZKA (HR) UMETAK	(IT) TIRANTE (GB) COUPLER (E) TIRANTE (D) KÖPPLER (F) TIRANT (NL) TREKSTANG (H) ROZSZITO BETÉT (PL) LĄPKA (SLO) SPOJ (HR) ZAKAČKA
ALFA ROMEO 159 SW (06>11) Rail aperti/Open rails/Mit Reiling/Railing	SI/YES/YA/OU	2
AUDI A3 Sportback 5P (04>08) Rail chiusi/Integrated rails/Geschlossener Reiling/Railing integrés	SI/YES/YA/OU	1
AUDI A3 Sportback 5P (08>12) Rail chiusi/Integrated rails/Geschlossener Reiling/Railing integrés	SI/YES/YA/OU	1
AUDI A3 Sportback 5P (12>) Rail chiusi/Integrated rails/Geschlossener Reiling/Railing integrés	SI/YES/YA/OU	1
AUDI A4 Allroad SW (09>16) Rail aperti/Open rails/Mit Reiling/Railing	SI/YES/YA/OU	1
AUDI A4 Avant SW (08>15) Rail chiusi/Integrated rails/Geschlossener Reiling/Railing integrés	SI/YES/YA/OU	1
AUDI A4 Avant SW (15>) Rail chiusi/Integrated rails/Geschlossener Reiling/Railing integrés	SI/YES/YA/OU	1
AUDI A6 Allroad SW (12>) Rail aperti/Open rails/Mit Reiling/Railing	SI/YES/YA/OU	1
AUDI A6 Avant SW (05>11) Rail chiusi/Integrated rails/Geschlossener Reiling/Railing integrés	SI/YES/YA/OU	1
AUDI A6 Avant SW (11>18) Rail chiusi/Integrated rails/Geschlossener Reiling/Railing integrés	SI/YES/YA/OU	1
AUDI A6 Avant SW (18>) Rail chiusi/Integrated rails/Geschlossener Reiling/Railing integrés	SI/YES/YA/OU	1
AUDI Q3 SUV (11>18) Rail chiusi/Integrated rails/Geschlossener Reiling/Railing integrés	SI/YES/YA/OU	1
AUDI Q3 SUV (18>) Rail chiusi/Integrated rails/Geschlossener Reiling/Railing integrés	SI/YES/YA/OU	1
AUDI Q5 SUV (08>16) Rail chiusi/Integrated rails/Geschlossener Reiling/Railing integrés	SI/YES/YA/OU	1
AUDI Q5 SUV (17>) Rail chiusi/Integrated rails/Geschlossener Reiling/Railing integrés	SI/YES/YA/OU	1
AUDI Q7 SUV (06>09) Rail chiusi/Integrated rails/Geschlossener Reiling/Railing integrés	SI/YES/YA/OU	1
AUDI Q7 SUV (09>15) Rail chiusi/Integrated rails/Geschlossener Reiling/Railing integrés	SI/YES/YA/OU	1
BMW Serie 2 Active Tourer MPV (14>) Rail chiusi/Integrated rails/Geschlossener Reiling/Railing integrés	SI/YES/YA/OU	1
BMW Serie 2 Gran Tourer MPV (15>) Rail chiusi/Integrated rails/Geschlossener Reiling/Railing integrés	SI/YES/YA/OU	1
BMW Serie 3 Touring SW (10>12) Rail chiusi/Integrated rails/Geschlossener Reiling/Railing integrés	SI/YES/YA/OU	1
BMW Serie 3 Touring SW (12>) Rail chiusi/Integrated rails/Geschlossener Reiling/Railing integrés	SI/YES/YA/OU	1
BMW Serie 5 Touring SW (10>17) Rail chiusi/Integrated rails/Geschlossener Reiling/Railing integrés	SI/YES/YA/OU	1
BMW X1 SUV (09>15) Rail chiusi/Integrated rails/Geschlossener Reiling/Railing integrés	SI/YES/YA/OU	1
BMW X1 SUV (15>) Rail chiusi/Integrated rails/Geschlossener Reiling/Railing integrés	SI/YES/YA/OU	1
BMW X3 SUV (10>17) Rail chiusi/Integrated rails/Geschlossener Reiling/Railing integrés	SI/YES/YA/OU	1
BMW X5 SUV (07>13) Rail chiusi/Integrated rails/Geschlossener Reiling/Railing integrés	SI/YES/YA/OU	1
CADILLAC SRX SUV (10>) Rail aperti/Open rails/Mit Reiling/Railing	SI/YES/YA/OU	2
CHEVROLET / DAEWOO Captiva SUV (06>15) Rail aperti/Open rails/Mit Reiling/Railing	SI/YES/YA/OU	2
CHEVROLET / DAEWOO Cruze SW (08>16) Rail aperti/Open rails/Mit Reiling/Railing	NO/NO/NEIN/NON	1
CITROËN C3 Picasso MPV (09>) Rail aperti/Open rails/Mit Reiling/Railing	SI/YES/YA/OU	1
CITROËN C4 Aircross SUV (12>) Rail chiusi/Integrated rails/Geschlossener Reiling/Railing integrés	SI/YES/YA/OU	2
CITROËN C5 II Tourer SW (08>) Rail aperti/Open rails/Mit Reiling/Railing	NO/NO/NEIN/NON	1
DACIA Logan II MCV SW (13>) Rail aperti/Open rails/Mit Reiling/Railing	NO/NO/NEIN/NON	1
DACIA Sandero Stepway II SUV (13>) Rail aperti/Open rails/Mit Reiling/Railing	NO/NO/NEIN/NON	1
DR DR 5 SUV (07>18) Rail aperti/Open rails/Mit Reiling/Railing	SI/YES/YA/OU	2
FIAT 500X SUV (15>) Rail chiusi/Integrated rails/Geschlossener Reiling/Railing integrés	NO/NO/NEIN/NON	1
FIAT Panda II 5P (03>12) Rail aperti/Open rails/Mit Reiling/Railing	NO/NO/NEIN/NON	2
FIAT Panda III 5P (12>) Rail chiusi/Integrated rails/Geschlossener Reiling/Railing integrés	SI/YES/YA/OU	2
FIAT Panda III Cross 5P (14>) Rail aperti/Open rails/Mit Reiling/Railing	SI/YES/YA/OU	2
FIAT Tipo II SW (16>) Rail chiusi/Integrated rails/Geschlossener Reiling/Railing integrés	NO/NO/NEIN/NON	2
FORD Edge SUV (16>) Rail chiusi/Integrated rails/Geschlossener Reiling/Railing integrés	SI/YES/YA/OU	2
FORD Fiesta VII Active SUV (17>) Rail chiusi/Integrated rails/Geschlossener Reiling/Railing integrés	NO/NO/NEIN/NON	1
FORD Focus III SW (11>18) Rail chiusi (no rail in plastica)/Integrated rails (no plastic rails)/Geschlossener Reiling/Railing integrés (ne pas de rails en matière plastique)	SI/YES/YA/OU	1
FORD Focus IV SW (18>) Rail chiusi/Integrated rails/Geschlossener Reiling/Railing integrés	SI/YES/YA/OU	1
FORD Focus IV Active 5P (19>) Rail chiusi/Integrated rails/Geschlossener Reiling/Railing integrés	NO/NO/NEIN/NON	1
FORD Mondeo V SW (15>) Rail chiusi/Integrated rails/Geschlossener Reiling/Railing integrés	SI/YES/YA/OU	2
HONDA Civic IX Tourer SW (13>) Rail chiusi/Integrated rails/Geschlossener Reiling/Railing integrés	SI/YES/YA/OU	1
HYUNDAI ix35 SUV (10>15) Rail chiusi/Integrated rails/Geschlossener Reiling/Railing integrés	SI/YES/YA/OU	2
HYUNDAI Kona SUV (17>) Rail chiusi/Integrated rails/Geschlossener Reiling/Railing integrés	SI/YES/YA/OU	2
HYUNDAI Tucson III SUV (15>18) Rail chiusi/Integrated rails/Geschlossener Reiling/Railing integrés	SI/YES/YA/OU	2
KIA Carens MPV (13>) Rail chiusi/Integrated rails/Geschlossener Reiling/Railing integrés	SI/YES/YA/OU	2
KIA Cee'd Sporty Wagon SW (12>) Rail chiusi/Integrated rails/Geschlossener Reiling/Railing integrés	SI/YES/YA/OU	2
KIA Niro SUV (16>) Rail chiusi/Integrated rails/Geschlossener Reiling/Railing integrés	SI/YES/YA/OU	2
KIA Sportage III SUV (10>15) Rail chiusi/Integrated rails/Geschlossener Reiling/Railing integrés	SI/YES/YA/OU	2
KIA Sportage IV SUV (16>) Rail chiusi/Integrated rails/Geschlossener Reiling/Railing integrés	SI/YES/YA/OU	2
MERCEDES Classe C SW (07>14) Rail aperti/Open rails/Mit Reiling/Railing	SI/YES/YA/OU	1
MERCEDES Classe C SW (14>) Rail chiusi/Integrated rails/Geschlossener Reiling/Railing integrés	SI/YES/YA/OU	1
MERCEDES Classe E SW (09>16) Rail aperti/Open rails/Mit Reiling/Railing	SI/YES/YA/OU	1
MERCEDES Classe M SUV (11>15) Rail aperti/Open rails/Mit Reiling/Railing	SI/YES/YA/OU	2
MERCEDES GLA SUV (13>) Rail chiusi/Integrated rails/Geschlossener Reiling/Railing integrés	SI/YES/YA/OU	1
MERCEDES GLC SUV (15>) Rail chiusi/Integrated rails/Geschlossener Reiling/Railing integrés	SI/YES/YA/OU	1
MERCEDES GLE SUV (15>18) Rail aperti/Open rails/Mit Reiling/Railing	SI/YES/YA/OU	2
MINI Countryman 5P (10>16) Rail chiusi/Integrated rails/Geschlossener Reiling/Railing integrés	SI/YES/YA/OU	1
MINI Countryman 5P (17>) Rail aperti/Open rails/Mit Reiling/Railing	SI/YES/YA/OU	1
MITSUBISHI ASX SUV (10>) Rail chiusi/Integrated rails/Geschlossener Reiling/Railing integrés	SI/YES/YA/OU	2
MITSUBISHI Outlander III SUV (12>) Rail chiusi/Integrated rails/Geschlossener Reiling/Railing integrés	SI/YES/YA/OU	2
NISSAN Gashqai II SUV (13>) Rail aperti/Open rails/Mit Reiling/Railing	SI/YES/YA/OU	2
NISSAN X-Trail III SUV (14>) Rail aperti/Open rails/Mit Reiling/Railing	SI/YES/YA/OU	1
OPEL Astra H SW (04>10) Rail chiusi/Integrated rails/Geschlossener Reiling/Railing integrés	SI/YES/YA/OU	1
OPEL Astra J Sport Tourer SW (11>15) Rail chiusi/Integrated rails/Geschlossener Reiling/Railing integrés	SI/YES/YA/OU	1
OPEL Insignia Sports Tourer SW (09>17) Rail chiusi/Integrated rails/Geschlossener Reiling/Railing integrés	SI/YES/YA/OU	1
OPEL Mokka SUV (12>16) Rail chiusi/Integrated rails/Geschlossener Reiling/Railing integrés	SI/YES/YA/OU	1
OPEL Mokka X SUV (16>) Rail chiusi/Integrated rails/Geschlossener Reiling/Railing integrés	SI/YES/YA/OU	1
OPEL Vectra C SW (03>05) Rail chiusi/Integrated rails/Geschlossener Reiling/Railing integrés	SI/YES/YA/OU	1
OPEL Vectra C SW (06>08) Rail chiusi/Integrated rails/Geschlossener Reiling/Railing integrés	SI/YES/YA/OU	1
OPEL Zafira B MPV (05>15) Rail chiusi/Integrated rails/Geschlossener Reiling/Railing integrés	SI/YES/YA/OU	1

	(IT) MODELLI AUTO (GB) CARS (E) COCHES (D) WAGEN (F) VOITURES (NL) AUTO (P) MODELO AUTO (H) AUTO TIPUS (PL) MODELE SAMOCHODOW (SLO) MODELI AVTOMOBILOV (HR) MODELI AUTA	(IT) INSERTO (GB) INSERT (E) CUNA (E) TIRANTE (D) DUBEL (F) TAMPON (NL) INVOEGSTUK (H) BESZURAS (PL) WKLADKA (SLO) VLOZKA (HR) UMETAK	(IT) TIRANTE (GB) COUPLER (E) TIRANTE (D) KOPPLER (F) TIRANT (NL) TREKSTANG (H) ROGZITO BETÉT (PL) LAPKA (SLO) SPOJ (HR) ZAKAČKA
OPEL Zafira C MPV (11>)	Rail chiusi/Integrated rails/Geschlossener Reling/Railing intégrés	SI/YES/YA/OUI	1
PEUGEOT 508 I SW (11>18)	Rail chiusi/Integrated rails/Geschlossener Reling/Railing intégrés	SI/YES/YA/OUI	2
PEUGEOT 3008 II MPV (16>)	Rail chiusi/Integrated rails/Geschlossener Reling/Railing intégrés	SI/YES/YA/OUI	2
PEUGEOT 308 II SW (14>)	Rail chiusi/Integrated rails/Geschlossener Reling/Railing intégrés	SI/YES/YA/OUI	1
PEUGEOT 5008 II MPV (17>)	Rail chiusi/Integrated rails/Geschlossener Reling/Railing intégrés	SI/YES/YA/OUI	2
RENAULT Clio IV Sporter / Grandtour SW (13>)	Rail aperti/Open rails/Mit Reling/Railing	NO/NO/NEIN/NON	1
RENAULT Grand Scenic IV MPV (16>)	7 posti/rail chiusi/7 seats/integrated rails/7 Sitzer/geschlossener Reling/7 places/railing intégrés	NO/NO/NEIN/NON	1
RENAULT Kadjar SUV (15>)	Rail chiusi/Integrated rails/Geschlossener Reling/Railing intégrés	SI/YES/YA/OUI	1
RENAULT Koleos II SUV (17>)	Rail chiusi/Integrated rails/Geschlossener Reling/Railing intégrés	SI/YES/YA/OUI	1
RENAULT Megane III Sportour / Grandtour SW (09>16)	Rail aperti/Open rails/Mit Reling/Railing	SI/YES/YA/OUI	2
RENAULT Megane IV Sporter SW (16>)	Rail chiusi/Integrated rails/Geschlossener Reling/Railing intégrés	NO/NO/NEIN/NON	1
RENAULT Talisman Sporter SW (16>)	Rail chiusi/Integrated rails/Geschlossener Reling/Railing intégrés	SI/YES/YA/OUI	2
SEAT Alhambra II MPV (10>)	Rail aperti/Open rails/Mit Reling/Railing	SI/YES/YA/OUI	1
SEAT Altea Freetrack MPV (07>)	Rail chiusi/Integrated rails/Geschlossener Reling/Railing intégrés	SI/YES/YA/OUI	1
SEAT Altea XL MPV (06>)	Rail chiusi/Integrated rails/Geschlossener Reling/Railing intégrés	SI/YES/YA/OUI	1
SEAT Arona SUV (17>)	Rail aperti/Open rails/Mit Reling/Railing	SI/YES/YA/OUI	1
SEAT Ateca SUV (16>)	Rail aperti/Open rails/Mit Reling/Railing	SI/YES/YA/OUI	2
SEAT Ibiza ST SW (10>)	Rail chiusi/Integrated rails/Geschlossener Reling/Railing intégrés	SI/YES/YA/OUI	1
SEAT Leon ST SW (13>)	Rail chiusi/Integrated rails/Geschlossener Reling/Railing intégrés	SI/YES/YA/OUI	1
SEAT Leon X-PERIENCE SW (15>)	Rail chiusi/Integrated rails/Geschlossener Reling/Railing intégrés	SI/YES/YA/OUI	1
SEAT Terraco SUV (18>)	Rail aperti/Open rails/Mit Reling/Railing	SI/YES/YA/OUI	1
SKODA Karoq SUV (17>)	Rail aperti/Open rails/Mit Reling/Railing	SI/YES/YA/OUI	1
SKODA Kodiaq SUV (17>)	Rail aperti/Open rails/Mit Reling/Railing	NO/NO/NEIN/NON	2
SKODA Superb III Wagon SW (15>)	Rail aperti/Open rails/Mit Reling/Railing	SI/YES/YA/OUI	1
SUZUKI Ignis III 5P (16>)	Rail aperti/Open rails/Mit Reling/Railing	SI/YES/YA/OUI	2
SUZUKI SX4 S-Cross 5P (13>)	Rail chiusi/Integrated rails/Geschlossener Reling/Railing intégrés	SI/YES/YA/OUI	1
SUZUKI Vitara SUV (15>)	Rail chiusi/Integrated rails/Geschlossener Reling/Railing intégrés	SI/YES/YA/OUI	2
TOYOTA Auris Touring Sports SW (13>18)	Rail chiusi/Integrated rails/Geschlossener Reling/Railing intégrés	SI/YES/YA/OUI	1
VOLKSWAGEN Cross Polo V 5P (10>)	Rail aperti/Open rails/Mit Reling/Railing	SI/YES/YA/OUI	1
VOLKSWAGEN Cross Up! 5P (14>)	Rail aperti/Open rails/Mit Reling/Railing	SI/YES/YA/OUI	1
VOLKSWAGEN Golf Sportsvan MPV (14>)	Rail aperti/Open rails/Mit Reling/Railing	SI/YES/YA/OUI	2
VOLKSWAGEN Golf VII Variant SW (13>)	Rail aperti/Open rails/Mit Reling/Railing	SI/YES/YA/OUI	2
VOLKSWAGEN Passat VIII Variant SW (14>)	Rail chiusi/Integrated rails/Geschlossener Reling/Railing intégrés	SI/YES/YA/OUI	1
VOLKSWAGEN Tiguan I SUV (07>16)	Rail aperti/Open rails/Mit Reling/Railing	SI/YES/YA/OUI	2
VOLKSWAGEN Tiguan II SUV (16>)	Rail aperti/Open rails/Mit Reling/Railing	SI/YES/YA/OUI	1
VOLKSWAGEN Touran II MPV (15>)	Rail aperti/Open rails/Mit Reling/Railing	SI/YES/YA/OUI	1
VOLKSWAGEN T-Cross SUV (18>)	Rail aperti/Open rails/Mit Reling/Railing	NO/NO/NEIN/NON	1
VOLVO V40 Cross Country SW (12>)	Rail aperti/Open rails/Mit Reling/Railing	SI/YES/YA/OUI	2
VOLVO V50 SW (04>12)	Rail aperti/Open rails/Mit Reling/Railing	NO/NO/NEIN/NON	1
VOLVO V60 I SW (10>18)	Rail chiusi/Integrated rails/Geschlossener Reling/Railing intégrés	SI/YES/YA/OUI	1
VOLVO V60 Cross Country SW (16>)	Rail chiusi/Integrated rails/Geschlossener Reling/Railing intégrés	SI/YES/YA/OUI	1
VOLVO V90 SW (16>)	Rail chiusi/Integrated rails/Geschlossener Reling/Railing intégrés	SI/YES/YA/OUI	1
VOLVO V90 Cross Country SW (16>)	Rail chiusi/Integrated rails/Geschlossener Reling/Railing intégrés	SI/YES/YA/OUI	1
VOLVO XC60 I SUV (10>17)	Rail chiusi/Integrated rails/Geschlossener Reling/Railing intégrés	SI/YES/YA/OUI	2
VOLVO XC60 II SUV (17>)	Rail chiusi/Integrated rails/Geschlossener Reling/Railing intégrés	SI/YES/YA/OUI	2
VOLVO XC90 II SUV (15>)	Rail chiusi/Integrated rails/Geschlossener Reling/Railing intégrés	SI/YES/YA/OUI	1