

(IT) Attenzione: Istruzioni di montaggio per barre in alluminio.
(GB) Attention: Mounting instructions for aluminium bar carriers.
(E) Atención: Instrucciones de montaje para barras portatodo en aluminio.
(D) Achtung: Montageanweisungen für Aluminium-Lastenträger.
(F) Attention: Notices de montage pour barres de portage en aluminium.
(NL) Attentie: Handleiding voor dakdragers gemaakt van aluminium.
(P) Atenção: Instruções de montagem para barras de tejadilho em alumínio.
(H) Szerelési utasítás alumínium tartórudakhoz.
(PL) Uwaga: Instrukcja montażu bagażników wykonanych ze aluminium.
(SLO) Pozor: Navodila za montažo nosilcev prtljažnika - aluminijastih.
(HR) Uputstvo za montažu aluminijaskih nosača.

1 **MERCEDES:** Classe A 5P (05->12)
 Classe A Coupè 3P (05->12)
 Classe B MPV (05->11)

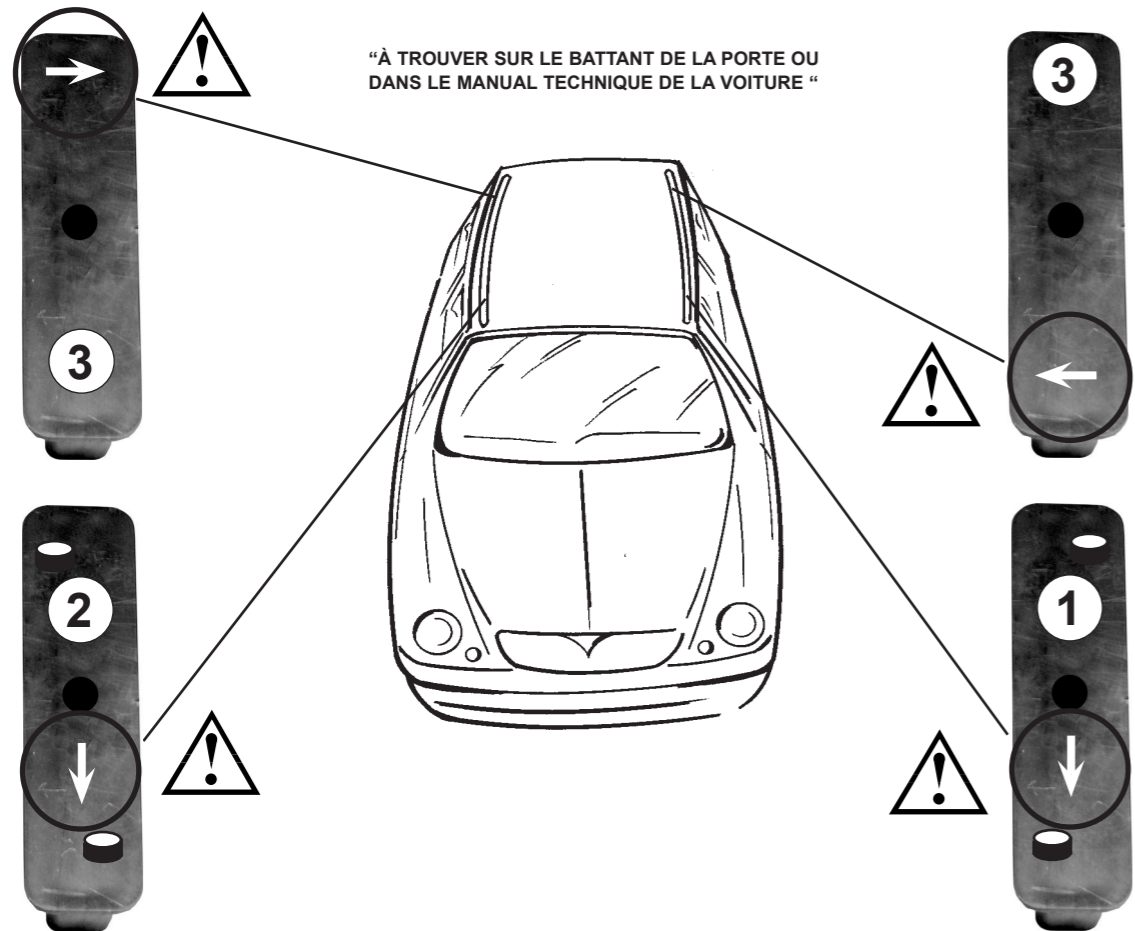
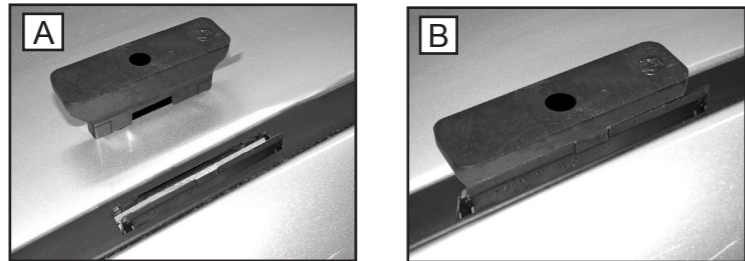

2 **ZOOM**

(A)
(IT) SVITARE
(GB) UNSCREW
(E) AFLOJAR
(D) ABSCHRAUBEN
(F) DEVISSER
(NL) OPENSCHROEVEN
(P) DESAPARAFUSAR
(H) KICSAVARNI
(PL) WYKRECIC
(SLO) ODVITI
(HR) ODVITI

(B)

(C)

(D)

(IT) INSERIRE
(GB) INSERT
(E) CUBRIR
(D) STOPFEN
(F) ENFILER
(NL) BEVESTIG

(P) INSERIR
(H) TOLJA FEL
(PL) NALOZIC
(SLO) VSTAVITI
(HR) PREKRITI

(IT) AVVITARE
(GB) TO SCREW
(E) APRETAR
(D) FESTSCHRAUBEN
(F) VISSER
(NL) VASTSCHROEVEN

(P) APERTAR
(H) MEGHÚZNI
(PL) WKRECIC
(SLO) PRIVITI
(HR) PRIČVRSTITI

3

ZOOM

(IT) INSERIRE
(GB) INSERT
(E) CUBRIR
(D) STOPFEN
(F) ENFILER
(NL) BEVESTIG

(P) INSERIR
(H) TOLJA FEL
(PL) NALOZIC
(SLO) VSTAVITI
(HR) PREKRITI

4

(IT) INSERIRE
(GB) INSERT
(E) CUBRIR
(D) STOPFEN
(F) ENFILER
(P) INSERIR
(NL) BEVESTIG
(H) TOLJA FEL
(PL) NALOZIC
(SLO) VSTAVITI
(HR) PREKRITI

(B)

5

(IT) TAGLIARE
(GB) TO CUT
(E) CORTAR
(D) SCHNEIDEN
(F) COUPER
(NL) SNIJDEN
(P) CORTAR
(H) ELVÁGNI
(PL) OBCIAC
(SLO) ODREZATI
(HR) ODREZATI

(A)

(B)

(IT) INSERIRE
(GB) INSERT
(E) CUBRIR
(D) STOPFEN
(F) ENFILER
(P) INSERIR
(NL) BEVESTIG
(H) TOLJA FEL
(PL) NALOZIC
(SLO) VSTAVITI
(HR) PREKRITI

(IT) MODELLI CON PREDISPOSIZIONE DELLA CASA AUTO
(GB) CARS WITH PRE-EXISTING FIXING POINT FROM MANUFACTURER
(E) MODELOS CON PREDISPOSICION DEL FABRICANTE
(D) AUTOS MIT VOM HERSTELLER VORGESEHENE BEFESTIGUNGSPUNKTE
(F) VOITURES AVEC POINTS DE RÉPÈRE PREVUS PAR LE CONSTRUCTEUR
(NL) AUTO'S MET DOOR DE FABRIKANT VOORZIENE MONTAGEPUNTEN
(P) VIATURAS COM PONTOS DE FIXAÇÃO DO CONSTRUTOR PRÉ-EXISTENTES
(H) FELHÉLYEZÉS GYÁRTÓ ÁLTAL KIJELÖLT PONTRA
(PL) SAMOCHODY Z PRZEWIDZIANYMI PUNKTAMI UMOCOWANIA
(SLO) MODELI Z PREDVIDENIM LEŽIŠČEM S STRANI PROIZVAJALCA
(HR) TVORNIČKI PRIPREMLJENI MODELI

6

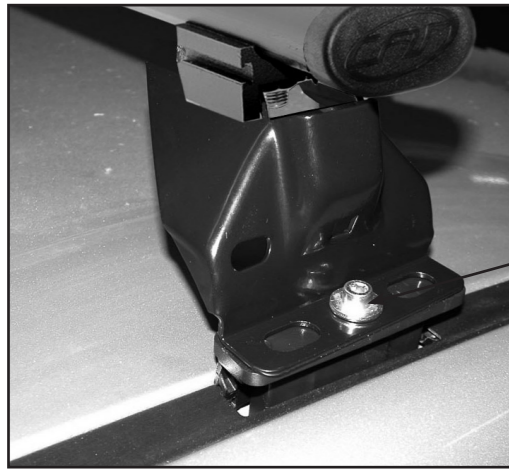

(IT) AVVITARE
(GB) TO SCREW
(E) APRETAR
(D) FESTSCHRAUBEN
(F) VISSER
(NL) VASTSCHROEVEN
(P) APERTAR
(H) MEGHÚZNI
(PL) WKRECIC
(SLO) PRIVITI
(HR) PRIČVRSTITI



5 Nm



(IT) POSTERIORE
(GB) REAR
(E) TRASERO
(D) HINTERE
(F) ARRIERE
(NL) ACHTERSTE G.
(P) ATRÁS
(H) HÁTSÓ RÚD
(PL) TYŁ
(SLO) ZADAJ
(HR) STRAŽNJI

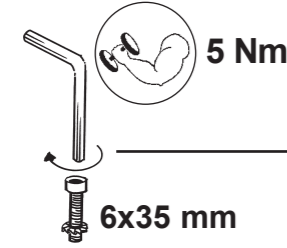

5 Nm

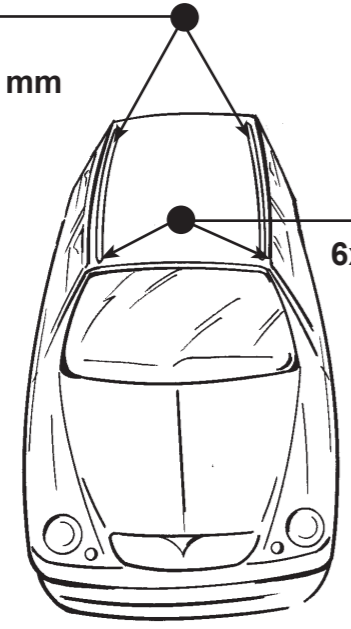

6x40 mm



5 Nm

(IT) ANTERIORE
(GB) FRONT
(E) DELANTERO
(D) VORDERE
(F) AVANT
(NL) VOORSTE G.
(P) À FRENTE
(H) ELSŐ RÚD
(PL) PRZOD
(SLO) SPREDAJ
(HR) PREDNJI

9

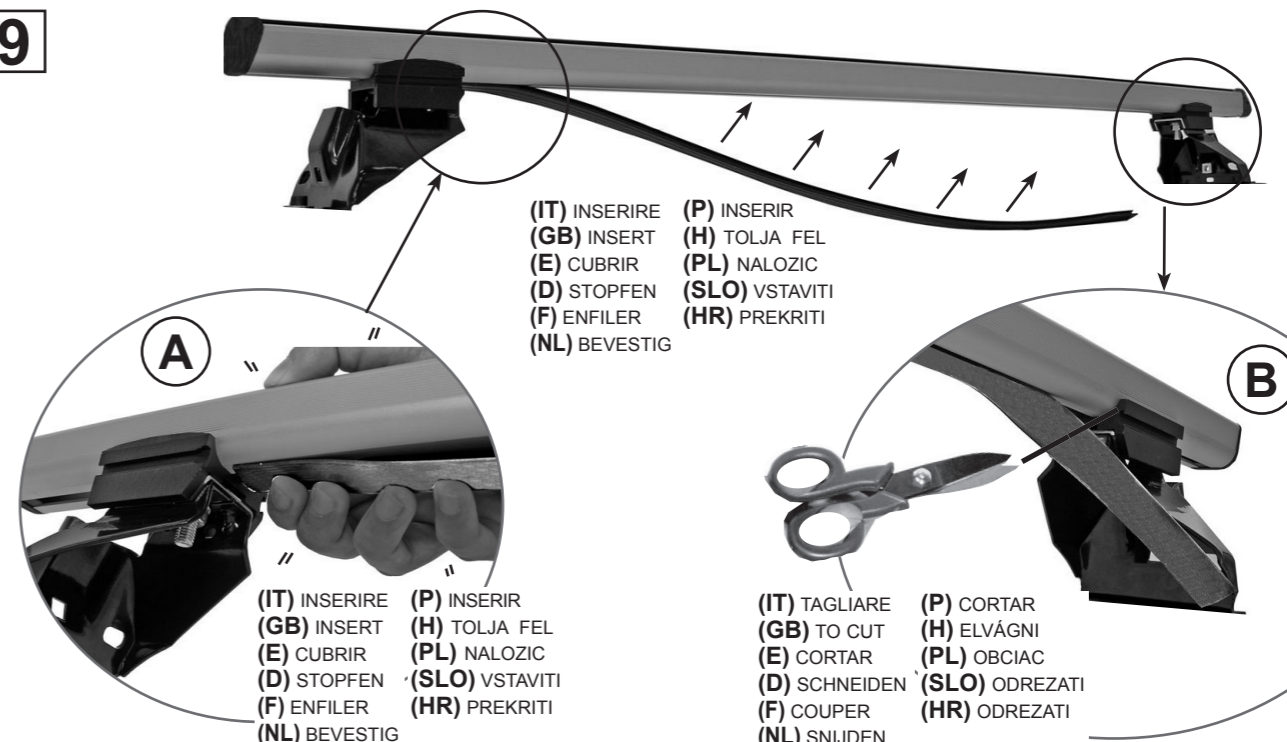

(IT) INSERIRE
(GB) INSERT
(E) CUBRIR
(D) STOPFEN
(F) ENFILER
(NL) BEVESTIG

(P) INSERIR
(H) TOLJA FEL
(PL) NALOZIC
(SLO) VSTAVITI
(HR) PREKRITI

A

(IT) INSERIRE
(GB) INSERT
(E) CUBRIR
(D) STOPFEN
(F) ENFILER
(NL) BEVESTIG

(P) INSERIR
(H) TOLJA FEL
(PL) NALOZIC
(SLO) VSTAVITI
(HR) PREKRITI

B

(IT) TAGLIARE
(GB) TO CUT
(E) CORTAR
(D) SCHNEIDEN
(F) COUPER
(NL) SNIJDEN

(P) CORTAR
(H) ELVÁGNI
(PL) OBCIAC
(SLO) ODREZATI
(HR) ODREZATI

(IT) CENTRARE IL P. TUTTO SUL TETTO
(GB) CENTRE THE UNIVERSAL BAR CARRIER ON THE ROOF
(E) CENTRAR EL PORTAEQUIPAJES SOBRE EL TECHO
(D) LASTENTRÄGER AUF DEM DACH ZENTRIEREN
(F) CENTRER LE PORTE-TOUT SUR LE TOIT
(NL) PLAATS DE UNIVERSELE DRAGER IN HET MIDDEN VAN HET DAK
(P) CENTRAR AS BARRAS PORTA BAGAGENS NO TEJADILHO
(H) HELYEZZE KÖZÉPRE A RUDAKAT
(PL) WYSRODKOWAC BAGAZNIK NA DACHU
(SLO) CENTRIRATI PRTLJAŽNIK NA STREHO
(HR) CENTRIRATI NOSAČE NA KROV

7

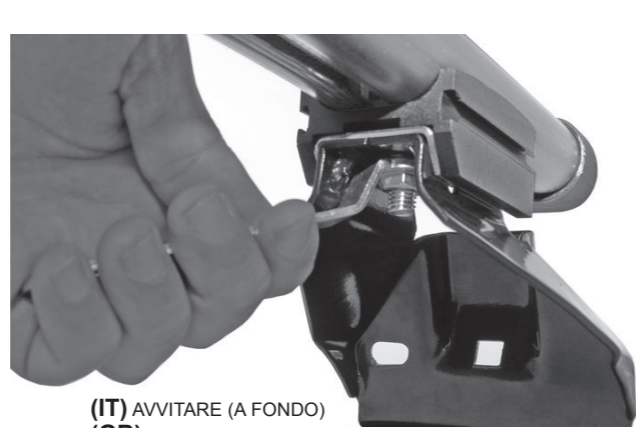
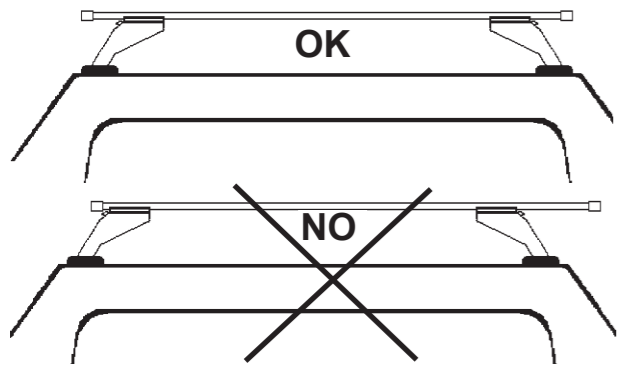



8

(IT) AVVITARE (A FONDO)
(GB) TO SCREW (DOWN)
(E) APRETAR (A FONDO)
(D) FESTSCHRAUBEN
(F) VISSER (À FOND)
(NL) VASTSCHROEVEN
(P) APERTAR POR BAIXO
(H) MEGHÚZNI
(PL) WKRECIC DO KONCA
(SLO) PRIVITI (DO KONCA)
(HR) PRIČVRSTITI (DO KRAJA)



10 Nm







(IT) **Attenzione:** Istruzioni di montaggio per barre in ferro.
 (GB) **Attention:** Mounting instructions for steel bar carriers.
 (E) **Atencion:** Instrucciones de montaje para barras portatodo en hierro.
 (D) **Achtung:** Montageanweisungen für Stahl-Lastenträger.
 (F) **Attention:** Notices de montage pour barres de portage en métal.
 (NL) **Attentie:** Handleiding voor dakdragers gemaakt van ijzer.
 (P) **Atenção:** Instrukções de montagem para barras de tejadilho em ferro.
 (H) Szerelési utasítás acél tartórudakhoz.
 (PL) **Uwaga:** Instrukcja montażu bagażników wykonanych ze stali.
 (SLO) **Pozor:** Navodila za montažo nosilcev prtljažnika-železnih.
 (HR) Uputstvo za montažu željeznih krovnih nosača.

1

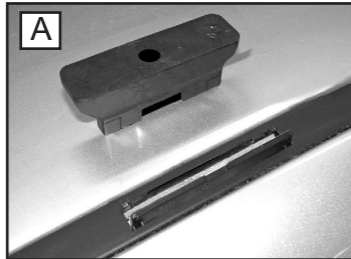
MERCEDES: Classe A 5P (05->12)
 Classe A Coupè 3P (05->12)
 Classe B MPV (05->11)



A



B

"À TROUVER SUR LE BATTANT DE LA PORTE OU DANS LE MANUAL TECHNIQUE DE LA VOITURE"

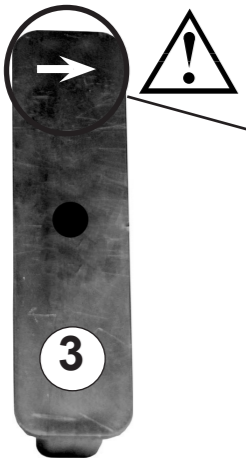

3

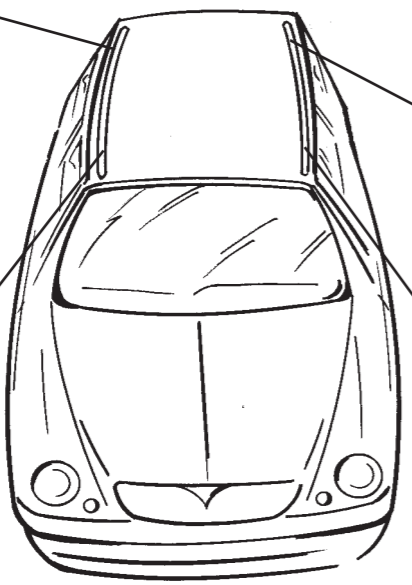

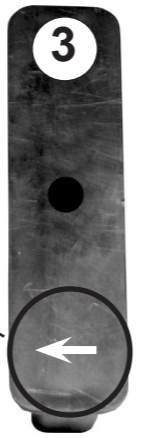

3

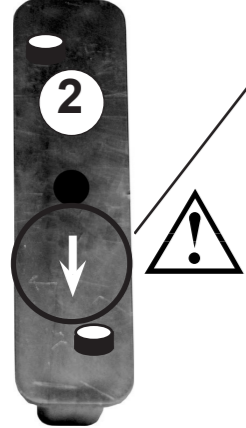

2

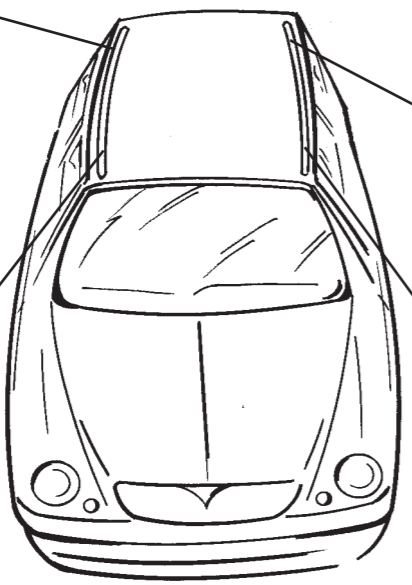

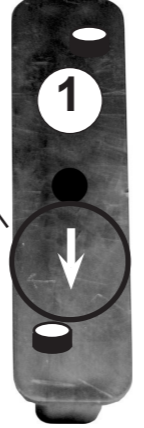

1

2

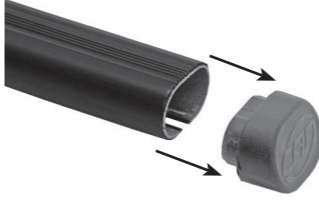

3

(IT) INSERIRE
(GB) INSERT
(E) CUBRIR
(D) STOPFEN
(F) ENFILER
(NL) BEVESTIG
(P) INSERIR
(H) TOLJA FEL
(PL) NALOZIC
(SLO) VSTAVITI
(HR) PREKRITI

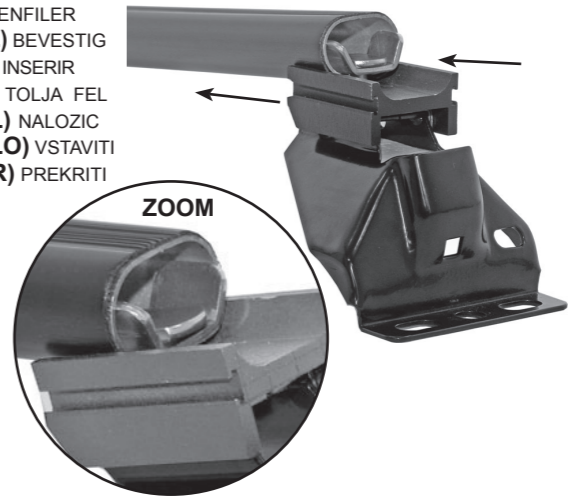

ZOOM

4



(IT) INSERIRE
(GB) INSERT
(E) CUBRIR
(D) STOPFEN
(F) ENFILER
(NL) BEVESTIG
(P) INSERIR
(H) TOLJA FEL
(PL) NALOZIC
(SLO) VSTAVITI
(HR) PREKRITI

5

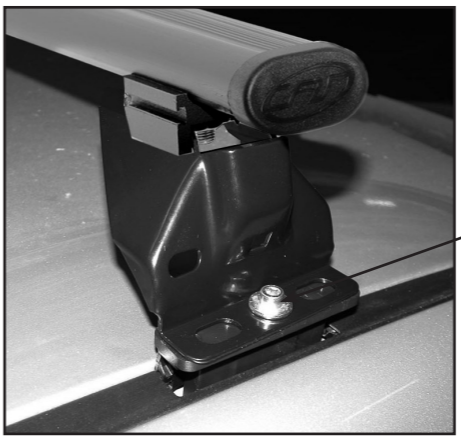

(IT) MODELLI CON PREDISPOSIZIONE DELLA CASA AUTO
(GB) CARS WITH PRE-EXISTING FIXING POINT FROM MANUFACTURER
(E) MODELOS CON PREDISPOSICION DEL FABRICANTE
(D) AUTOS MIT VOM HERSTELLER VORGESEHENE BEFESTIGUNGSPUNKTE
(F) VOITURES AVEC POINTS DE RÉPÈRE PREVUS PAR LE CONSTRUCTEUR
(NL) AUTO'S MET DOOR DE FABRIKANT VOORZIENE MONTAGEPUNTEN
(P) VIATURAS COM PONTOS DE FIXAÇÃO DO CONSTRUTOR PRÉ-EXISTENTES
(H) FELHELYEZÉS GYÁRTÓ ÁLTAL KIJELÖLT PONTRA
(PL) SAMOCHODY Z PRZEWIDZIANYMI PUNKTAMI UMOCOWANIA
(SLO) MODELI Z PREDVIDENIM LEŽIŠČEM S STRANI PROIZVAJALCA
(HR) TVORNIČKI PRIPREMLJENI MODELI

(IT) AVVITARE
(GB) TO SCREW
(E) APRETAR
(D) FESTSCHRAUBEN
(F) VISSER
(NL) VASTSCHROEVEN
(P) APERTAR
(H) MEGHÚZNI
(PL) WKRECIĆ
(SLO) PRIVITI
(HR) PRIČVRSTITI

5 Nm



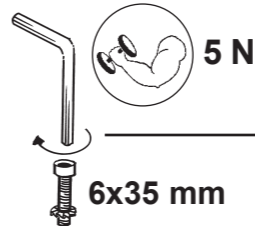

6x35 mm

(IT) POSTERIORE
(GB) REAR
(E) TRASERO
(D) HINTERE
(F) ARRIERE
(NL) ACHTERSTE G.
(P) ATRÁS
(H) HÁTSÓ RÚD
(PL) TYŁ
(SLO) ZADAJ
(HR) STRAŽNJI

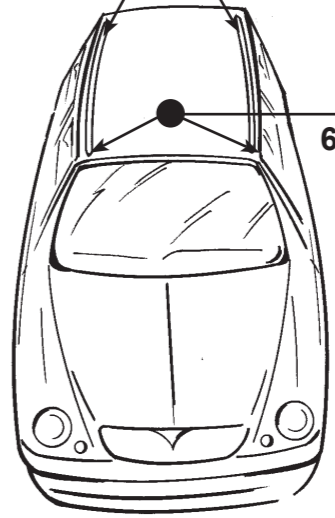

6x40 mm

(IT) ANTERIORE
(GB) FRONT
(E) DELANTERO
(D) VORDERE
(F) AVANT
(NL) VOORSTE G.
(P) À FRENTE
(H) ELSŐ RÚD
(PL) PRZOD
(SLO) SPREDAJ
(HR) PREDNJI

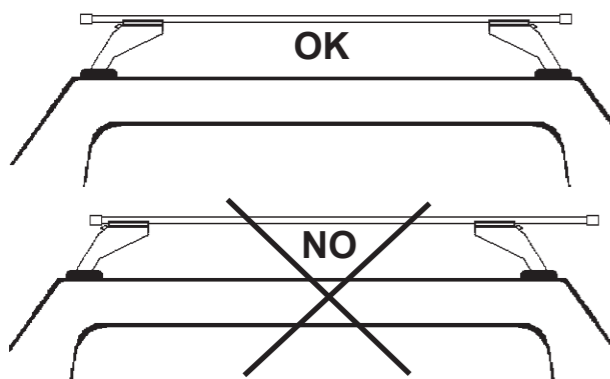

6

- (IT) CENTRARE IL P. TUTTO SUL TETTO
 (GB) CENTRE THE UNIVERSAL BAR CARRIER ON THE ROOF
 (E) CENTRAR EL PORTAEQUIPAJES SOBRE EL TECHO
 (D) LASTENTRÄGER AUF DEM DACH ZENTRIEREN
 (F) CENTRER LE PORTE-TOUT SUR LE TOIT
 (NL) PLAATS DE UNIVERSELE DRAGER IN HET MIDDEN VAN HET DAK
 (P) CENTRAR AS BARRAS PORTA BAGAGENS NO TEJADILHO
 (H) HELYEZZE KÖZÉPRE A RUDAKAT
 (PL) WYSRODKOWAC BAGAŻNIK NA DACHU
 (SLO) CENTRIRATI PRTLJAŽNIK NA STREHO
 (HR) CENTRIRATI NOSAČE NA KROV

7**10 Nm**

- (IT) AVVITARE (A FONDO)
 (GB) TO SCREW (DOWN)
 (E) APRETAR (A FONDO)
 (D) FESTSCHRAUBEN
 (F) VISSER (À FOND)
 (NL) VASTSCHROEVEN
 (P) APERTAR POR BAIXO
 (H) MEGHÚZNI
 (PL) WKRECIC DO KONCA
 (SLO) PRIVITI (DO KONCA)
 (HR) PRIČVRSTITI (DO KRAJA)

40098 PARTS LIST

x4 Cod. VTBS08P30



x4 Cod. 32052/Z



x4 Cod. ROZB08016



x4 Cod. DDFZ08001

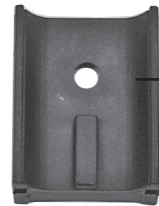

x4 Cod. 60328

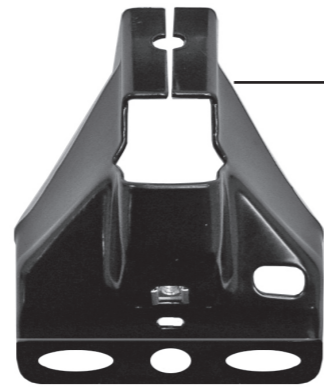

x4 Cod. 31060/V

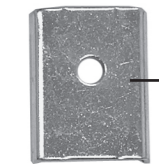

x4 Cod. 32053/Z

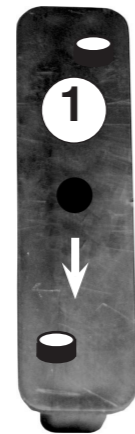

x1 Cod. 60248

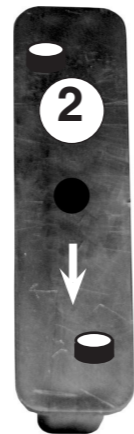

x1 Cod. 60249

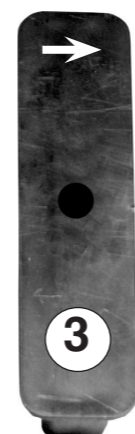

x2 Cod. 60250

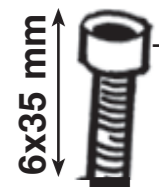

x2 Cod. VTBB06035

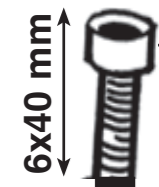

x2 Cod. VTBB06040

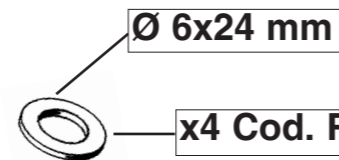

x4 Cod. ROZB06024



x4 Cod. 60243

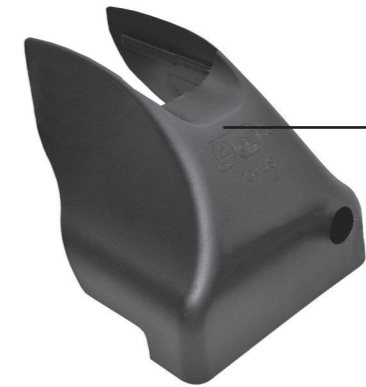

x4 Cod. 60239

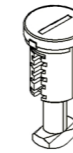

x4 Cod. 60263



x4 Cod. 60260



x1 Cod. 60273



x1 Cod. 57543



x1 Cod. 32032/Z

COVER TOTUS L

(IT) ISTRUZIONI DI MONTAGGIO (GB) FITTING INSTRUCTIONS (E) INSTRUCCIONES PARA SU MONTAJE
(D) MONTAGEANWEISUNGEN (F) INSTRUCTIONS DE MONTAGE (NL) MONTAGE INSTRUCTIES (P) INSTRUÇÕES DE MONTAGEM
(H) SZERELÉSI UTASÍTÁS (PL) INSTRUKCJA MONTAZU (SLO) NAVODILA O MONTAŽI (HR) UPUTE ZA MONTAŽU.

1



(IT) INSERIRE
(GB) INSERT
(E) CUBRIR
(D) STOPFEN
(F) ENFILER
(P) INSERIR
(NL) BEVESTIG
(H) TOLJA FEL
(PL) NALOZIC
(SLO) VSTAVITI
(HR) PREKRITI

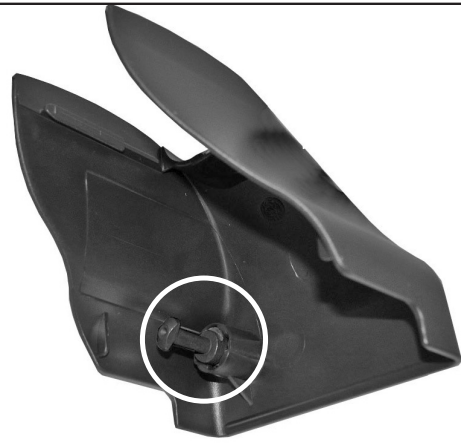

2



(IT) INSERIRE
(GB) INSERT
(E) CUBRIR
(D) STOPFEN
(F) ENFILER
(P) INSERIR
(NL) BEVESTIG
(H) TOLJA FEL
(PL) NALOZIC
(SLO) VSTAVITI
(HR) PREKRITI

3



4

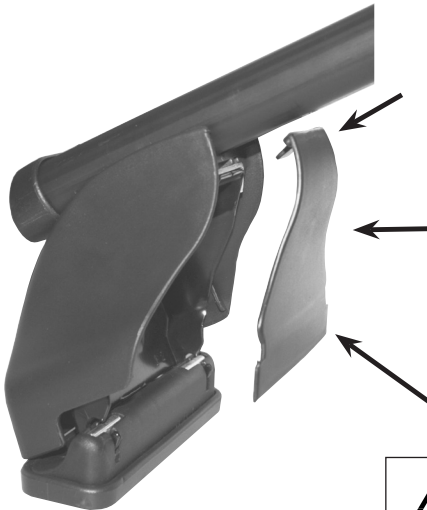

(IT) INSERIRE
(GB) INSERT
(E) CUBRIR
(D) STOPFEN
(F) ENFILER
(P) INSERIR
(NL) BEVESTIG
(H) TOLJA FEL
(PL) NALOZIC
(SLO) VSTAVITI
(HR) PREKRITI



NO PER ART. 40102 - 40115 - 40119

5

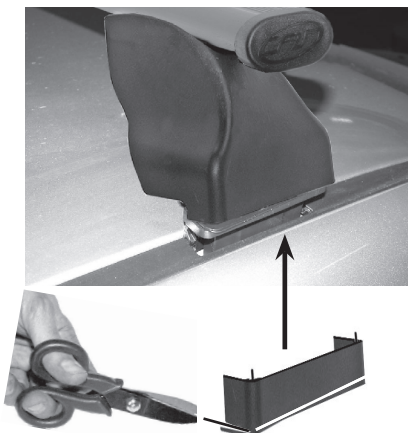

(IT) INSERIRE
(GB) INSERT
(E) CUBRIR
(D) STOPFEN
(F) ENFILER
(P) INSERIR
(NL) BEVESTIG
(H) TOLJA FEL
(PL) NALOZIC
(SLO) VSTAVITI
(HR) PREKRITI

