

(IT) MODELLI CON PREDISPOSIZIONE DELLA CASA AUTO
 (GB) CARS WITH PRE-EXISTING FIXING POINT FROM MANUFACTURER
 (E) MODELOS CON PREDISPOSICION DEL FABRICANTE
 (D) AUTOS MIT VOM HERSTELLER VORGESEHENE BEFESTIGUNGSPUNKTE
 (F) VOITURES AVEC POINTS DE RÉPÈRE PRÉVUS PAR LE CONSTRUCTEUR
 (NL) AUTO'S MET DEUR DE FABRIKANT VOORZIENE MONTAGEPUNTEN
 (P) VIATURAS COM PONTOS DE FIXAÇÃO DO CONSTRUTOR PRÉ-EXISTENTES
 (H) FELHÉLYEZÉS GYÁRTÓ ÁLTAL KIJELÖLT PONTRA
 (PL) SAMOCHODY Z PRZEWIDZIANYMI PUNKTAMI UMOCOWANIA
 (SLO) MODELI Z PREDVIDENIM LEŽIŠČEM S STRANI PROIZVAJALCA
 (HR) TVORNIČKI PRIPREMLJENI MODELI

“À TROUVER SUR LE BATTANT DE LA PORTE OU DANS LE MANUAL TECHNIQUE DE LA VOITURE “

11

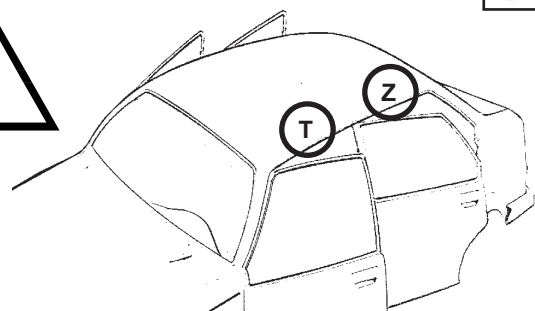

(IT) MODELLI AUTO (GB) CARS (E) COCHES (D) WAGEN (F) VOITURES (NL) AUTO (P) MODELO AUTO (H) AUTÓ TIPUS (PL) MODELE SAMOCHODÓW (SLO) MODELI AVTOMOBILOV (HR) MODELI AUTA	(IT) ANTERIORE (GB) FRONT (E) DELANTERO (D) VORDERE (F) AVANT (NL) VOORSTE G. (P) À FRENTE (H) ELSŐ RÚD (PL) PRZOD (SLO) SPREDAJ (HR) PREDNJI
---	---

RENAULT Captur II SUV (19>)	T
MITSUBISHI ASX II SUV (23>) No rails/ Ohne reling/Sauf railing	T

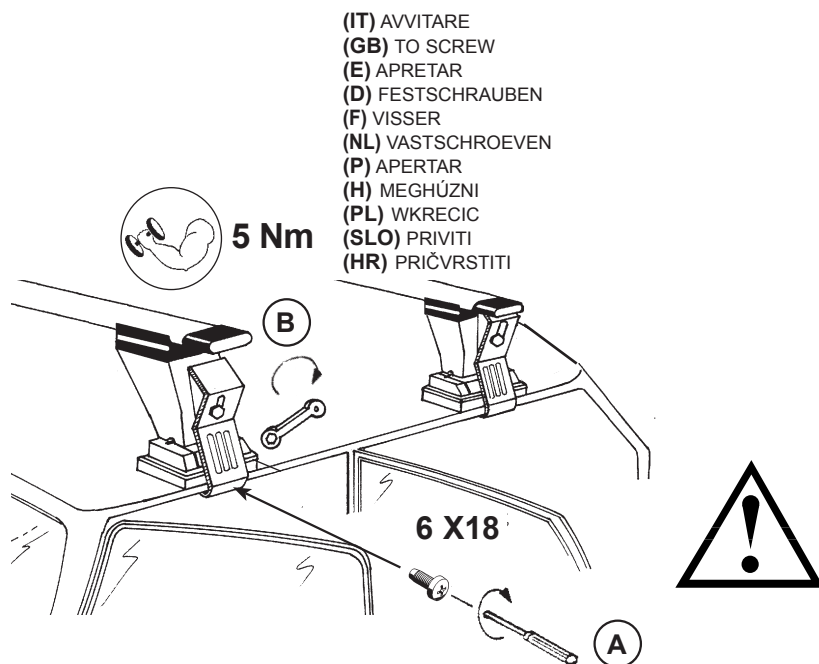
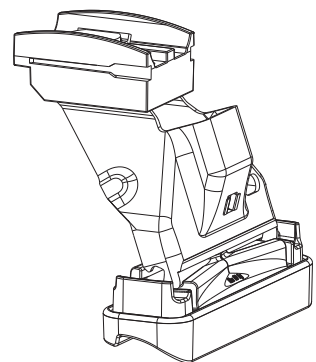

(IT) AVVITARE
(GB) TO SCREW
(E) APRETAR
(D) FESTSCHRAUBEN
(F) VISSER
(NL) VASTSCHROEVEN
(P) APERTAR
(H) MEGHÚZNI
(PL) WKRECIC
(SLO) PRIVITI
(HR) PRIČVRSTITI

(IT) MODELLI AUTO (GB) CARS (E) COCHES (D) WAGEN (F) VOITURES (NL) AUTO (P) MODELO AUTO (H) AUTÓ TIPUS (PL) MODELE SAMOCHODÓW (SLO) MODELI AVTOMOBILOV (HR) MODELI AUTA	(IT) POSTERIORE (GB) REAR (E) TRASERO (D) HINTERE (F) ARRIERE (NL) ACHTERSTE G. (P) ATRÁS (H) HÁTSÓ RÚD (PL) TYL (SLO) ZADAJ (HR) STRAŽNJI
---	--

(IT) AVVITARE
(GB) TO SCREW
(E) APRETAR
(D) FESTSCHRAUBEN
(F) VISSER
(NL) VASTSCHROEVEN
(P) APERTAR
(H) MEGHÚZNI
(PL) WKRECIC
(SLO) PRIVITI
(HR) PRIČVRSTITI

RENAULT Captur II SUV (19>)	Z
MITSUBISHI ASX II SUV (23>) No rails/ Ohne reling/Sauf railing	Z

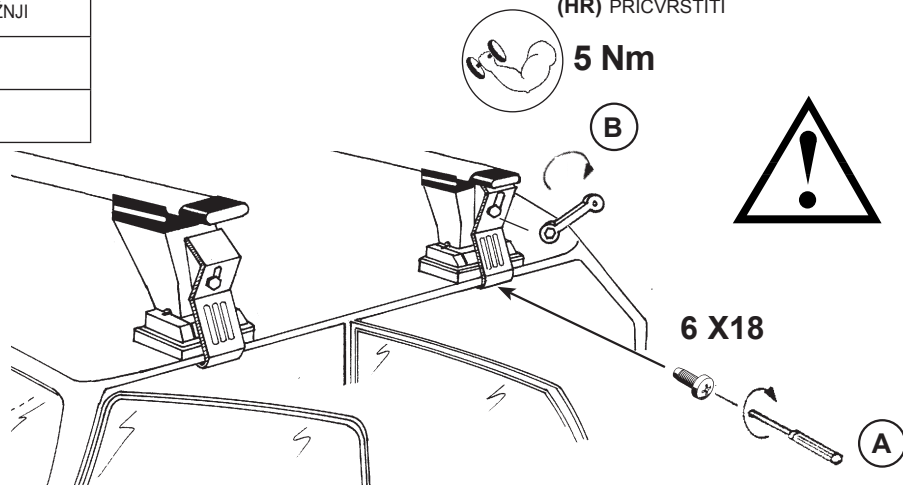
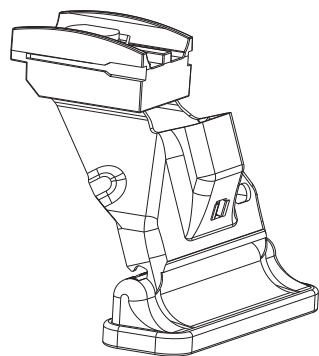

(IT) POSTERIORE
(GB) REAR
(E) TRASERO
(D) HINTERE
(F) ARRIERE
(NL) ACHTERSTE G.
(P) ATRÁS
(H) HÁTSÓ RÚD
(PL) TYL
(SLO) ZADAJ
(HR) STRAŽNJI

IST_40169_01_2311

40169 AL

40169 AL

40169 AL



(IT) **Attenzione:** Istruzioni di montaggio per barre in alluminio.
 (GB) **Attention:** Mounting instructions for aluminium bar carriers.
 (E) **Atencion:** Instrucciones de montaje para barras portatodo en aluminio.
 (D) **Achtung:** Montageanweisungen für Aluminium-Lastenträger.
 (F) **Attention:** Notices de montage pour barres de portage en aluminium.
 (NL) **Attentie:** Handleiding voor dakdragers gemaakt van aluminium.
 (P) **Atenção:** Instruções de montagem para barras de tejadilho em alumínio.
 (H) **Szerelési utasítás** aluminium tartórudakhoz.
 (PL) **Uwaga:** Instrukcja montażu bagażników wykonanych ze aluminium.
 (SLO) **Pozor:** Navodila za montažo nosilcev prtljažnika - aluminijastih.
 (HR) Uputstvo za montažu aluminijaskih nosača.

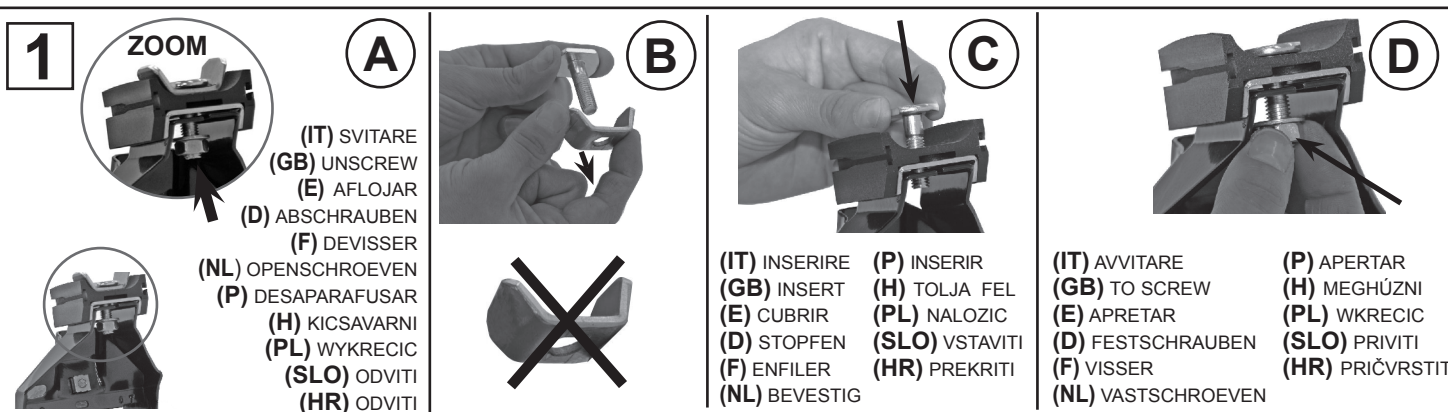

*Solo barre Totus AL / Only Totus AL bars / Solo barras Totus AL / Nur Totus AL Traverse / Seuls les bars Totus AL

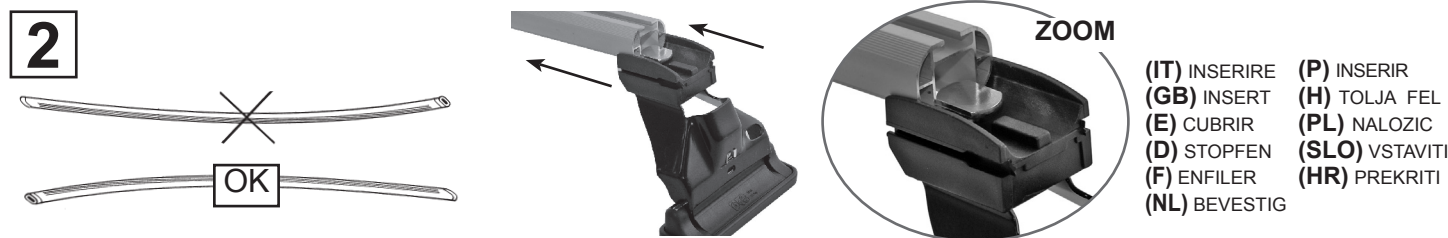

(IT) MODELLI AUTO (GB) CARS (E) COCHES (D) WAGEN (F) VOITURES	(NL) AUTO (P) MODELO AUTO (H) AUTÓ TIPUS (PL) MODELE SAMOCHODÓW (SLO) MODELI AVTOMOBILOV (HR) MODELI AUTA	(IT) ANTERIORE (GB) FRONT (E) DELANTERO (D) VORDERE (F) AVANT	(NL) VOORSTE G. (P) À FRENTE (H) ELSŐ RÚD (PL) PRZOD (SLO) SPREDAJ (HR) PREDNJI	(IT) POST. REAR (GB) REAR (E) TRASERO (D) HINTERE (F) ARRIERE	(NL) ACHTERSTE G. (P) ATRÁS (H) HÁTSÓ RÚD (PL) TYL (SLO) ZADAJ (HR) STRAŽNJI
RENAULT Captur II SUV (19>)		111 mm		145 mm	
MITSUBISHI ASX II SUV (23>) No rails/ Ohne reling/Sauf railing		111 mm		145 mm	



(IT) MISURE PRECISE
(GB) EXACT DIMENSIONS
(E) MEDIDAS CORRECTAS
(D) GENAUE MASSE
(F) MESURES EXACTES
(NL) EXACTE AFMETINGEN
(P) MEDIDAS PRECISAS
(H) PONTOS MÉRET
(PL) DOKŁADNE WYMIARY
(SLO) TOČNE MERE
(HR) PRECIZNE MJERE

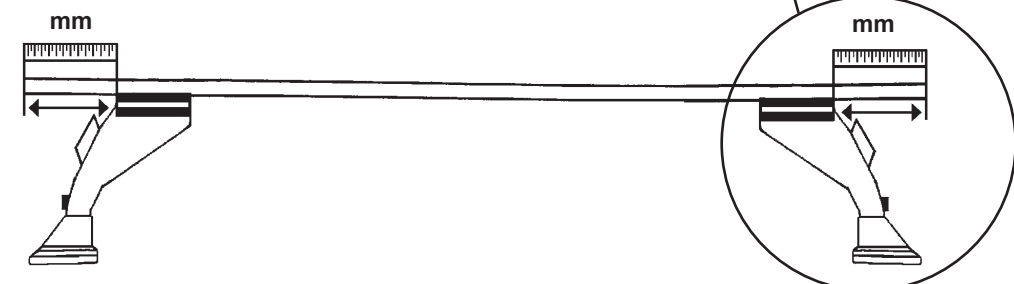

4

(IT) AVVITARE (A FONDO)
 (GB) TO SCREW (DOWN)
 (E) APRETAR (A FONDO)
 (D) FESTSCHRAUBEN
 (F) VISSER (À FOND)
 (NL) VASTSCHROEVEN
 (P) APERTAR POR BAIXO
 (H) MEGHÚZNI
 (PL) WKRECIĆ DO KONCA
 (SLO) PRIVITI (DO KONCA)
 (HR) PRIČVRSTITI (DO KRAJA)



10 Nm

5

(IT) INSERIRE
 (GB) INSERT
 (E) CUBRIR
 (D) STOPFEN
 (F) ENFILER
 (P) INSERIR
 (NL) BEVESTIG
 (H) TOLJA FEL
 (PL) NALOZIC
 (SLO) VSTAVITI
 (HR) PREKRITI

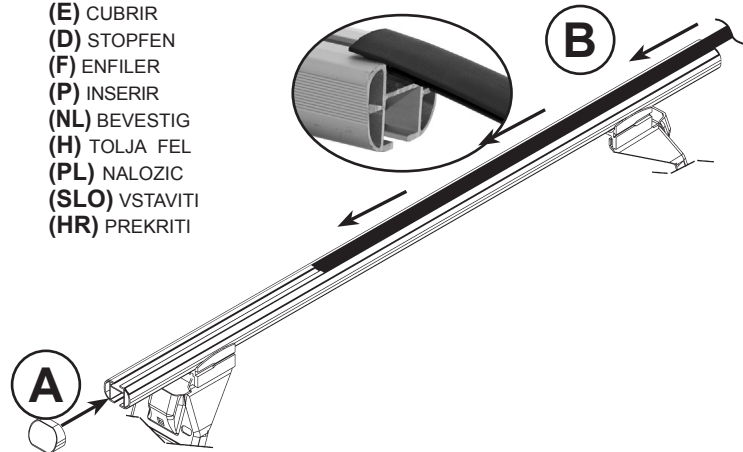

6

(IT) TAGLIARE
 (GB) TO CUT
 (E) CORTAR
 (D) SCHNEIDEN
 (F) COUPER
 (NL) SNIJDEN
 (P) CORTAR
 (H) ELVÁGNI
 (PL) OBCIAC
 (SLO) ODREZATI
 (HR) ODREZATI

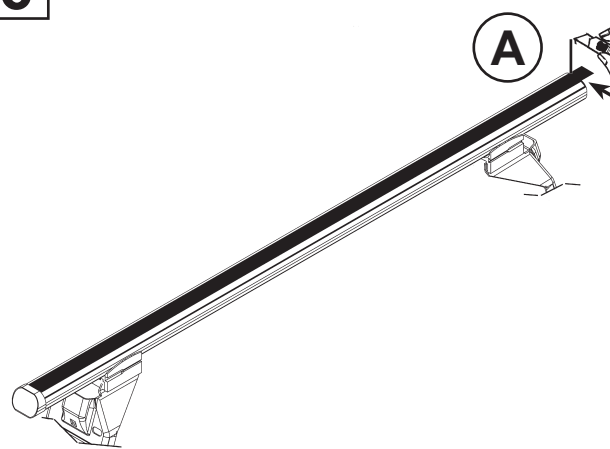

(IT) INSERIRE
 (GB) INSERT
 (E) CUBRIR
 (D) STOPFEN
 (F) ENFILER
 (P) INSERIR
 (NL) BEVESTIG
 (H) TOLJA FEL
 (PL) NALOZIC
 (SLO) VSTAVITI
 (HR) PREKRITI

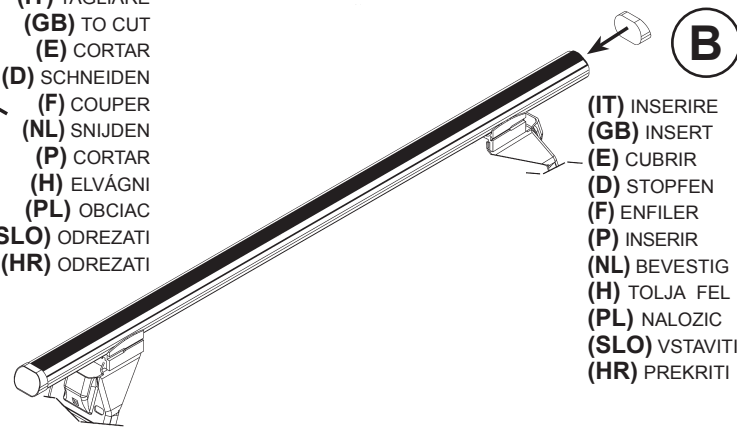

7

(IT) INSERIRE
 (GB) INSERT
 (E) CUBRIR
 (D) STOPFEN
 (F) ENFILER
 (NL) BEVESTIG

(P) INSERIR
 (H) TOLJA FEL
 (PL) NALOZIC
 (SLO) VSTAVITI
 (HR) PREKRITI

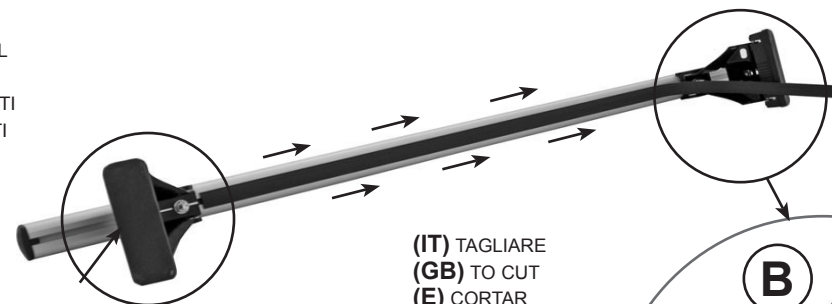

(IT) TAGLIARE
 (GB) TO CUT
 (E) CORTAR
 (D) SCHNEIDEN
 (F) COUPER
 (NL) SNIJDEN
 (P) CORTAR
 (H) ELVÁGNI
 (PL) OBCIAC
 (SLO) ODREZATI
 (HR) ODREZATI

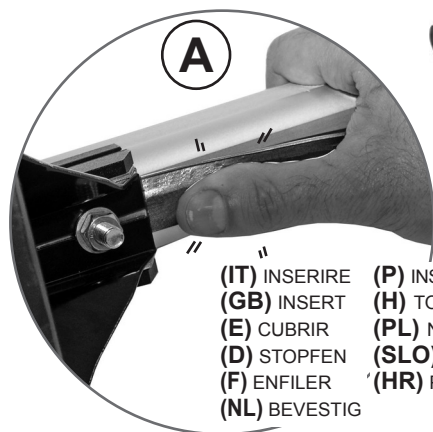

(IT) INSERIRE
 (GB) INSERT
 (E) CUBRIR
 (D) STOPFEN
 (F) ENFILER
 (NL) BEVESTIG

(P) INSERIR
 (H) TOLJA FEL
 (PL) NALOZIC
 (SLO) VSTAVITI
 (HR) PREKRITI

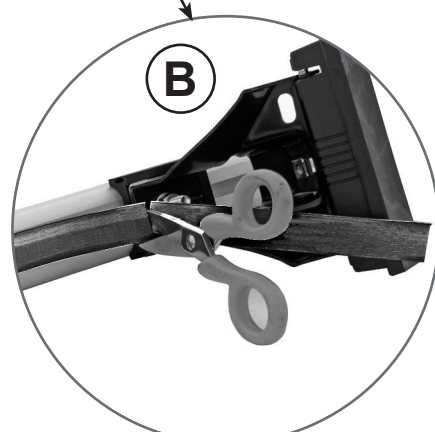

8

(IT) PULIRE IL TETTO
 (GB) CLEAN THE ROOF
 (E) LIMPIAR EL TECHO
 (D) DACH REINIGEN
 (F) NETTOYER LE TOIT
 (NL) DAK SCHOONMAKEN
 (P) LIMPAR O TEJADILHO
 (H) TISZTÍTSÁ MEG A TETŐT
 (PL) WYCZYŚCIC DACH
 (SLO) OČISTITI STREHO
 (HR) ČIŠĆENJE KROVA

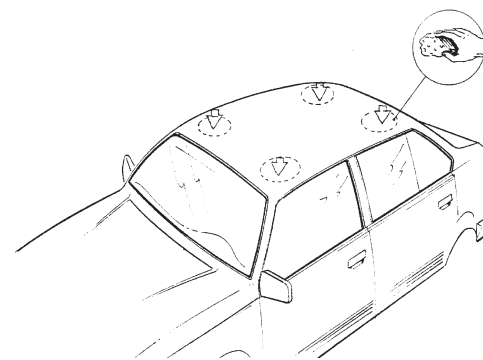

9

(IT) CENTRARE IL P. TUTTO SUL TETTO
 (GB) CENTRE THE UNIVERSAL BAR CARRIER ON THE ROOF
 (E) CENTRAR EL PORTAEQUIPAJES SOBRE EL TECHO
 (D) LASTENTRÄGER AUF DEM DACH ZENTRIEREN
 (F) CENTRER LE PORTE-TOUT SUR LE TOIT
 (NL) PLAATS DE UNIVERSELE DRAGER IN HET MIDDEN VAN HET DAK
 (P) CENTRAR AS BARRAS PORTA BAGAGENS NO TEJADILHO
 (H) HELYEZZE KÖZÉPRE A RUDAKAT
 (PL) WYSRODKOWAĆ BAGAZNIK NA DACHU
 (SLO) CENTRIRATI PRTLJAŽNIK NA STREHO
 (HR) CENTRIRATI NOSAČE NA KROV

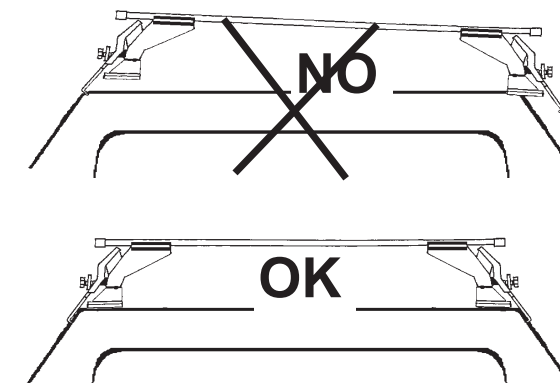

10



(IT) MODELLI AUTO
 (GB) CARS
 (E) COCHES
 (D) WAGEN
 (F) VOITURES
 (NL) AUTO
 (P) MODELO AUTO
 (H) AUTÓ TIPUS
 (PL) MODELE SAMOCHODÓW
 (SLO) MODELI AVTOMOBILOV
 (HR) MODELI AUTA

(IT) ANTERIORE
 (GB) FRONT
 (E) DELANTERO
 (D) VORDERE
 (F) AVANT
 (NL) VOORSTE G.
 (P) À FRENTE
 (H) ELSŐ RÚD
 (PL) PRZOD
 (SLO) SPREDAJ
 (HR) PREDNJI

(IT) POSTERIORE
 (GB) REAR
 (E) TRASERO
 (D) HINTERE
 (F) ARRIERE
 (NL) ACHTERSTE G.
 (P) ATRÁS
 (H) HÁTSÓ RÚD
 (PL) TYŁ
 (SLO) ZADAJ
 (HR) STRAŽNJI

RENAULT Captur II SUV (19>)

167

167P

MITSUBISHI ASX II SUV (23>) No rails/Ohne reling/Sauf railing

167

167P

(IT) MONTAGGIO GANASCINE
 (GB) HOW TO ASSEMBLE THE CLAMPS
 (E) COMO MONTAR LAS FIJACIONES
 (D) ZUSAMMENBAU DER SPANNBACKEN
 (F) MONTAGE PATTE
 (NL) MONTAGE VAN DE KLEMMEN
 (P) COMO FIXAR OS SUPORTES
 (H) RÖGZÍTŐ FÜLEK
 (PL) MONTAŻ SZCZEK MOCUJACYCH
 (SLO) MONTAŽA NAPENJALNIKA
 (HR) MONTAŽA ČELJUSTI

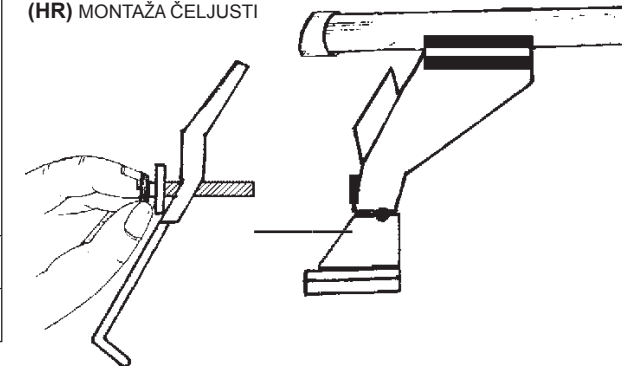
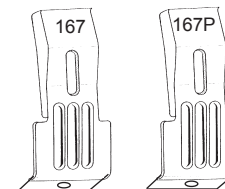

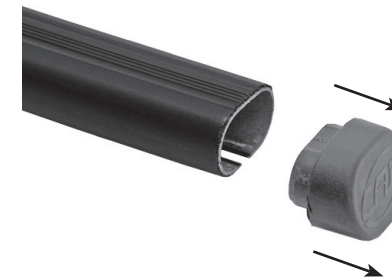
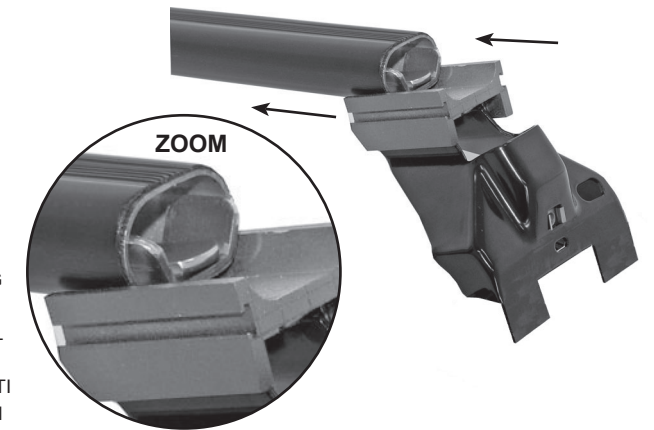

40169 FE**40169 FE****40169 FE**

(IT) **Attenzione:** Istruzioni di montaggio per barre in ferro.
 (GB) **Attention:** Mounting instructions for steel bar carriers.
 (E) **Atencion:** Instrucciones de montaje para barras portatodo en hierro.
 (D) **Achtung:** Montageanweisungen für Stahl-Lastenträger.
 (F) **Attention:** Notices de montage pour barres de portage en métal.
 (NL) **Attentie:** Handleiding voor dakdragers gemaakt van ijzer.
 (P) **Atenção:** Intruções de montagem para barras de tejadilho em ferro.
 (H) **Szerelési utasítás** acél tartórudakhoz.
 (PL) **Uwaga:** Instrukcja montażu bagazników wykonanych ze stali.
 (SLO) **Pozor:** Navodila za montažo nosilcev prtljažnika-železnih.
 (HR) **Uputstvo za** montažu željeznih krovnih nosača.

1**2**

(IT) INSERIRE
 (GB) INSERT
 (E) CUBRIR
 (D) STOPFEN
 (F) ENFILER
 (NL) BEVESTIG
 (P) INSERIR
 (H) TOLJA FEL
 (PL) NALOZIC
 (SLO) VSTAVITI
 (HR) PREKRITI

3

		
(IT) MODELLI AUTO (NL) AUTO (GB) CARS (P) MODELO AUTO (E) COCHES (H) AUTÓ TIPUS (D) WAGEN (PL) MODELE SAMOCHODÓW (F) VOITURES (SLO) MODELI AVTOMOBILOV (HR) MODELI AUTA	(IT) ANTERIORE (NL) VOORSTE G. (GB) FRONT (P) A FRENTE (E) DELANTERO (H) ELSÓ RÚD (D) VORDERE (PL) PRZOD (F) AVANT (SLO) SPREDAJ (HR) PREDNJI	(IT) POST. (NL) ACHTERSTE G. (GB) REAR (P) ATRÁS (E) TRASERO (H) HÁTSÓ RÚD (D) HINTERE (PL) TYŁ (F) ARRIERE (SLO) ZADAJ (HR) STRAŽNJI
RENAULT Captur II SUV (19>)	111 mm	145 mm
MITSUBISHI ASX II SUV (23>) No rails/ Ohne reling/Sauf railing	111 mm	145 mm

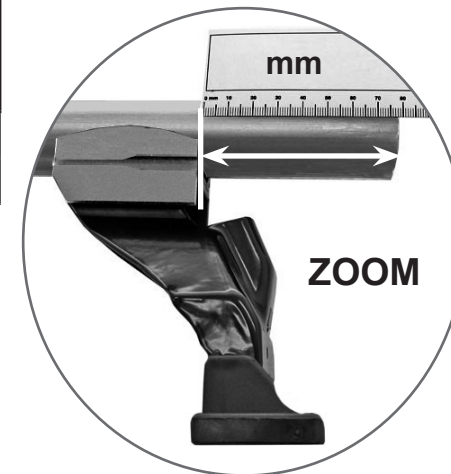

(IT) MISURE PRECISE
 (GB) EXACT DIMENSIONS
 (E) MEDIDAS CORRECTAS
 (D) GENAUE MASSE
 (F) MESURES EXACTES
 (NL) EXACTE AFMETINGEN
 (P) MEDIDAS PRECISAS
 (H) PONTOS MÉRET
 (PL) DOKŁADNE WYMIARY
 (SLO) TOČNE MERE
 (HR) PRECIZNE MJERE

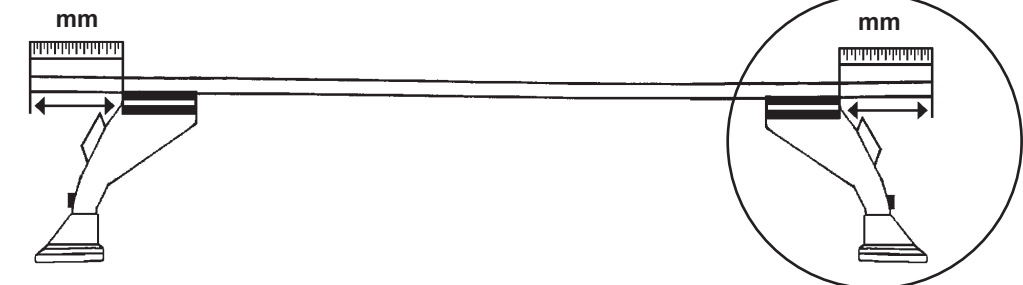

IST_40169_01_2311

4

10 Nm

(IT) AVVITARE (A FONDO)
(GB) TO SCREW (DOWN)
(E) APRETAR (A FONDO)
(D) FESTSCHRAUBEN
(F) VISSER (À FOND)
(NL) VASTSCHROEVEN
(P) APERTAR POR BAIXO
(H) MEGHÚZNI
(PL) WKRECIC DO KONCA
(SLO) PRIVITI (DO KONCA)
(HR) PRIČVRSTITI (DO KRAJA)

5

(IT) INSERIRE
(GB) INSERT
(E) CUBRIR
(D) STOPFEN
(F) ENFILER
(P) INSERIR
(NL) BEVESTIG
(H) TOLJA FEL
(PL) NALOZIC
(SLO) VSTAVITI
(HR) PREKRITI

6

(IT) PULIRE IL TETTO
(GB) CLEAN THE ROOF
(E) LIMPIAR EL TECHO
(D) DACH REINIGEN
(F) NETTOYER LE TOIT
(NL) DAK SCHOONMAKEN
(P) LIMPAR O TEJADILHO
(H) TISZTÍTSÁ MEG A TETŐT
(PL) WYCZYŚCIC DACH
(SLO) OČISTITI STREHO
(HR) ČIŠĆENJE KROVA

7

(IT) CENTRARE IL P. TUTTO SUL TETTO
(GB) CENTRE THE UNIVERSAL BAR CARRIER ON THE ROOF
(E) CENTRAR EL PORTAEQUIPAJES SOBRE EL TECHO
(D) LASTENTRÄGER AUF DEM DACH ZENTRIEREN
(F) CENTRER LE PORTE-TOUT SUR LE TOIT
(NL) PLAATS DE UNIVERSELE DRAGER IN HET MIDDEN VAN HET DAK
(P) CENTRAR AS BARRAS PORTA BAGAGENS NO TEJADILHO
(H) HELYEZZE KÖZÉPRE A RUDAKAT
(PL) WYSRODKOWAC BAGAŻNIK NA DACHU
(SLO) CENTRIRATI PRTLJAŽNIK NA STREHO
(HR) CENTRIRATI NOSAČE NA KROV

8

(IT) MONTAGGIO GANASCINE
(GB) HOW TO ASSEMBLE THE CLAMPS
(E) COMO MONTAR LAS FIJACIONES
(D) ZUSAMMENBAU DER SPANNBACKEN
(F) MONTAGE PATTE
(NL) MONTAGE VAN DE KLEMMEN
(P) COMO FIXAR OS SUPORTES
(H) RÖGZÍTŐ FÜLEK
(PL) MONTAŻ SZCZEK MOCUJĄCYCH
(SLO) MONTAŽA NAPENJALNIKA
(HR) MONTAŽA ČELJUSTI

	(IT) ANTERIORE (GB) FRONT (E) DELANTERO (D) VORDERE (F) AVANT (NL) VOORSTE G. (P) À FRENTE (H) ELSŐ RÚD (PL) PRZOD (SLO) SPREDAJ (HR) PREDNJI	(IT) POSTERIORE (GB) REAR (E) TRASERO (D) HINTERE (F) ARRIERE (NL) ACHTERSTE G. (P) ATRÁS (H) HÁTSÓ RÚD (PL) TYL (SLO) ZADAJ (HR) STRAŽNJI
RENAULT Captur II SUV (19>)	167	167P
MITSUBISHI ASX II SUV (23>) No rails/Ohne reling/Sauf railing	167	167P

(IT) MODELLI CON PREDISPOSIZIONE DELLA CASA AUTO
(GB) CARS WITH PRE-EXISTING FIXING POINT FROM MANUFACTURER
(E) MODELOS CON PREDISPOSICION DEL FABRICANTE
(D) AUTOS MIT VOM HERSTELLER VORGESEHENE BEFESTIGUNGSPUNKTE
(F) VOITURES AVEC POINTS DE RÉPÈRE PRÉVUS PAR LE CONSTRUCTEUR
(NL) AUTO'S MET DOOR DE FABRIKANT VOORZIENE MONTAGEPUNTEN
(P) VIATURAS COM PONTOS DE FIXAÇÃO DO CONSTRUTOR PRÉ-EXISTENTES
(H) FELHÉLYEZÉS GYÁRTÓ ÁLTAL KIJELÖLT PONTRA
(PL) SAMOCHODY Z PRZEWIDZIANYMI PUNKTAMI UMOCOWANIA
(SLO) MODELI Z PREDVIDENIM LEŽIŠČEM S STRANI PROIZVAJALCA
(HR) TVORNIČKI PRIPREMLJENI MODELI

9

“À TROUVER SUR LE BATTANT DE LA PORTE OU DANS LE MANUAL TECHNIQUE DE LA VOITURE “

(IT) ANTERIORE
(GB) FRONT
(E) DELANTERO
(D) VORDERE
(F) AVANT
(NL) VOORSTE G.
(P) À FRENTE
(H) ELSŐ RÚD
(PL) PRZOD
(SLO) SPREDAJ
(HR) PREDNJI

(IT) AVVITARE
(GB) TO SCREW
(E) APRETAR
(D) FESTSCHRAUBEN
(F) VISSER
(NL) VASTSCHROEVEN
(P) APERTAR
(H) MEGHÚZNI
(PL) WKRECIC
(SLO) PRIVITI
(HR) PRIČVRSTITI

5 Nm

6 X 18

(IT) MODELLI AUTO
(GB) CARS
(E) COCHES
(D) WAGEN
(F) VOITURES
(NL) AUTO
(P) MODELO AUTO
(H) AUTÓ TIPUS
(PL) MODELE SAMOCHODÓW
(SLO) MODELI AVTOMOBILOV
(HR) MODELI AUTA

(IT) POSTERIORE
(GB) REAR
(E) TRASERO
(D) HINTERE
(F) ARRIERE
(NL) ACHTERSTE G.
(P) ATRÁS
(H) HÁTSÓ RÚD
(PL) TYL
(SLO) ZADAJ
(HR) STRAŽNJI

(IT) AVVITARE
(GB) TO SCREW
(E) APRETAR
(D) FESTSCHRAUBEN
(F) VISSER
(NL) VASTSCHROEVEN
(P) APERTAR
(H) MEGHÚZNI
(PL) WKRECIC
(SLO) PRIVITI
(HR) PRIČVRSTITI

RENAULT Captur II SUV (19>)	T
MITSUBISHI ASX II SUV (23>) No rails/Ohne reling/Sauf railing	T

(IT) MODELLI AUTO
(GB) CARS
(E) COCHES
(D) WAGEN
(F) VOITURES
(NL) AUTO
(P) MODELO AUTO
(H) AUTÓ TIPUS
(PL) MODELE SAMOCHODÓW
(SLO) MODELI AVTOMOBILOV
(HR) MODELI AUTA

(IT) POSTERIORE
(GB) REAR
(E) TRASERO
(D) HINTERE
(F) ARRIERE
(NL) ACHTERSTE G.
(P) ATRÁS
(H) HÁTSÓ RÚD
(PL) TYL
(SLO) ZADAJ
(HR) STRAŽNJI

(IT) AVVITARE
(GB) TO SCREW
(E) APRETAR
(D) FESTSCHRAUBEN
(F) VISSER
(NL) VASTSCHROEVEN
(P) APERTAR
(H) MEGHÚZNI
(PL) WKRECIC
(SLO) PRIVITI
(HR) PRIČVRSTITI

5 Nm

6 X 18

RENAULT Captur II SUV (19>)	Z
MITSUBISHI ASX II SUV (23>) No rails/Ohne reling/Sauf railing	Z

(IT) POSTERIORE
(GB) REAR
(E) TRASERO
(D) HINTERE
(F) ARRIERE
(NL) ACHTERSTE G.

(P) ATRÁS
(H) HÁTSÓ RÚD
(PL) TYL
(SLO) ZADAJ
(HR) STRAŽNJI

40169 PARTS LIST

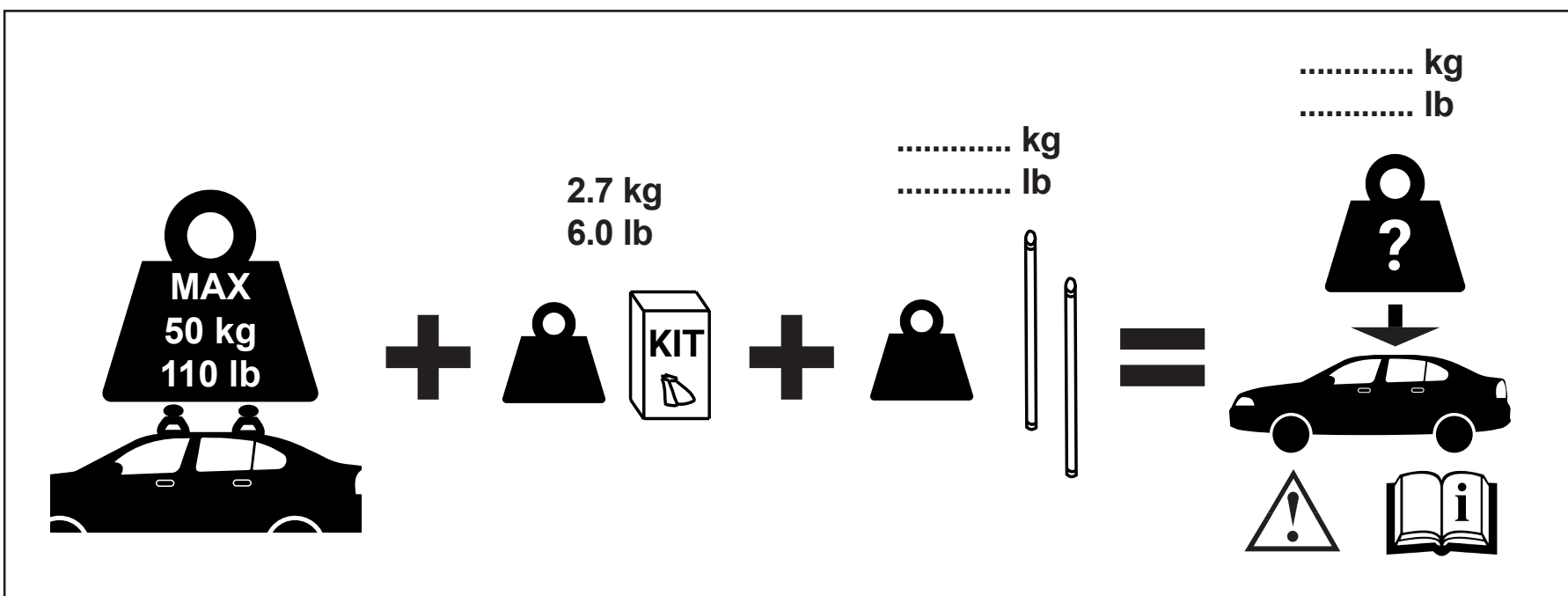
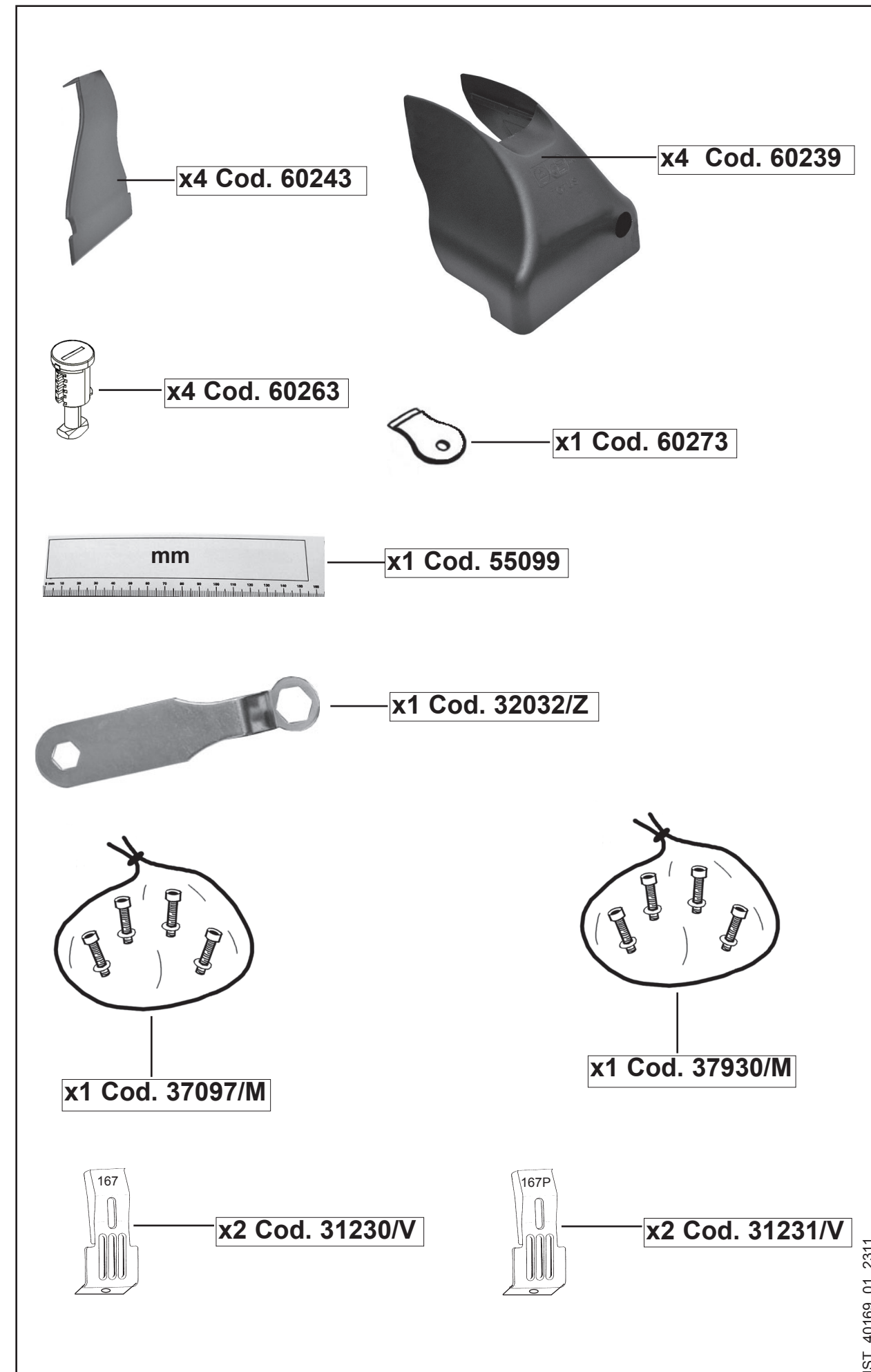
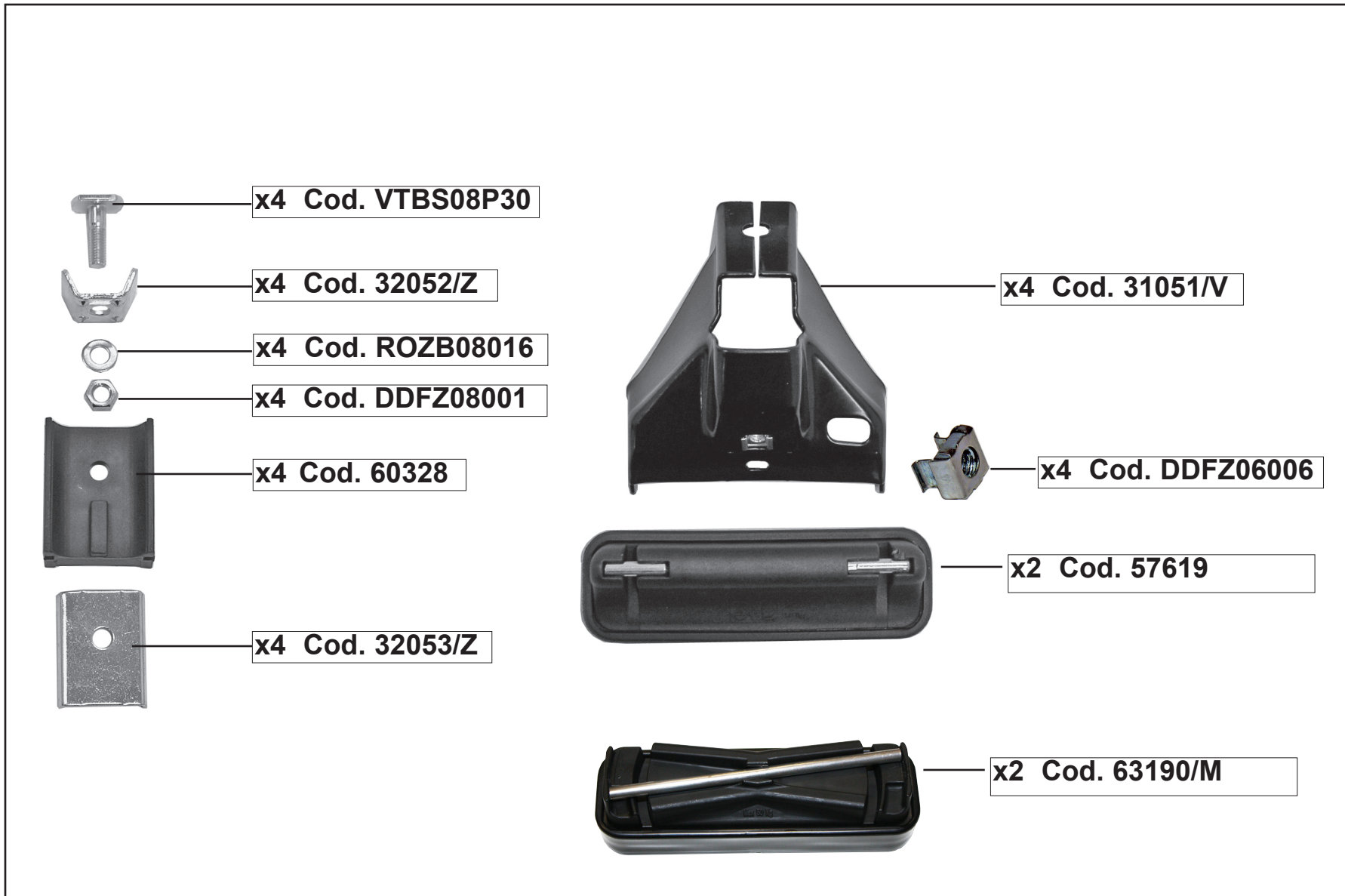

COVER TOTUS

(IT) ISTRUZIONI DI MONTAGGIO (GB) FITTING INSTRUCTIONS (E) INSTRUCCIONES PARA SU MONTAJE
(D) MONTAGEANWEISUNGEN (F) INSTRUCTIONS DE MONTAGE (NL) MONTAGE INSTRUCTIES (P) INSTRUÇÕES DE MONTAGEM
(H) SZERELÉSI UTASÍTÁS (PL) INSTRUKCJA MONTAŻU (SLO) NAVODILA O MONTAŽI (HR) UPUTE ZA MONTAŽU.

1



(IT) INSERIRE
(GB) INSERT
(E) CUBRIR
(D) STOPFEN
(F) ENFILER
(P) INSERIR
(NL) BEVESTIG
(H) TOLJA FEL
(PL) NALOZIC
(SLO) VSTAVITI
(HR) PREKRITI



2



(IT) INSERIRE
(GB) INSERT
(E) CUBRIR
(D) STOPFEN
(F) ENFILER
(P) INSERIR
(NL) BEVESTIG
(H) TOLJA FEL
(PL) NALOZIC
(SLO) VSTAVITI
(HR) PREKRITI

3



4

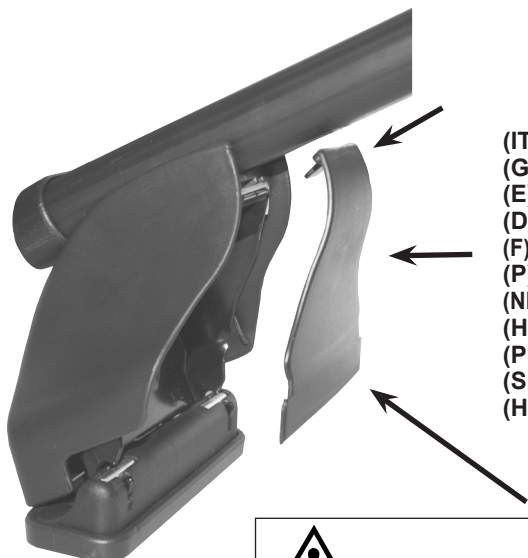

(IT) INSERIRE
(GB) INSERT
(E) CUBRIR
(D) STOPFEN
(F) ENFILER
(P) INSERIR
(NL) BEVESTIG
(H) TOLJA FEL
(PL) NALOZIC
(SLO) VSTAVITI
(HR) PREKRITI



NO PER ART. 40102 - 40115 - 40119